

CT MOLDINGS,inc

MOLDING & MILLWORK
CATALOG

spring 2017

RYSZARD KLOS
cell (203) 667 - 4528
ryszard@ctmoldings.com

DARIUSZ A. FRANEK
cell (203) 253 - 5420
dariusz@ctmoldings.com

308 Bishop Ave. Bridgeport, CT 06610
office (203) 612 - 4922 | fax (203) 612 - 4923
info@ctmoldings.com

www.ctmoldings.com



FABRICATING UNIQUE CUSTOM PIECES FOR THE HIGH END MILLWORK MARKET

With over 50 years of combined experience, CT Moldings compromises to create fine millwork pieces held to the highest workmanship standards of traditional Architecture.

With state of the art technology capable of manufacturing custom profiles to your specification in just about any wood species.

Majority of the wood is grown, harvested and milled in the U.S.A. Using quality lumber and paying attention to detail is our first priority.

We can provide consultation on historic preservation pieces as well as help you through the process of designing from scratch a unique and custom piece in order to complement your vision.

We have the local warehouse capabilities for stocking an extensive inventory of millwork products as well as a complete showroom to give our clients the opportunity to preview and select a full range of moldings.

CAD & PDF FILES AVAILABLE TO DOWNLOAD ON

www.ctmoldings.com

CT Moldings, inc has great experience dealing with Architects, Contractors and direct Clients. Our wood shop offers the ability to create custom millwork including size, color and specific details to suit the needs of their projects.

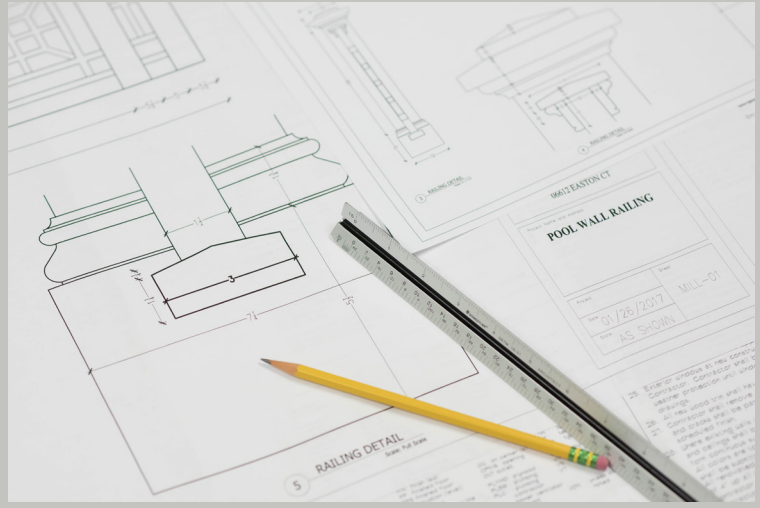

From base cap to wainscot, below is our latest catalog with all the standard sizes available ready for pickup or delivery. However, we are eager to accept any custom made order and deliver with minimal turnaround time.



We use high class machines that complete your orders in a quick however efficient manner. Don't confuse us with molding resellers, we are factory direct. Therefore, everything is manufactured by us, on the finest equipment and held to the highest standards.





TABLE OF CONTENTS

Backband	page 05
Base Cap	page 07
Beaded Edge	page 12
Cap Molding.....	page 15
Casing	page 22
Chair Rail	page 33
Cove	page 38
Crown	page 40
Solid Crown	page 57
Edging	page 61
Fluted	page 66
Mullion	page 68
Panel Molding	page 71
Plinth Block	page 86
Raised Panel	page 89
Shoe Molding	page 92
Wainscot	page 95

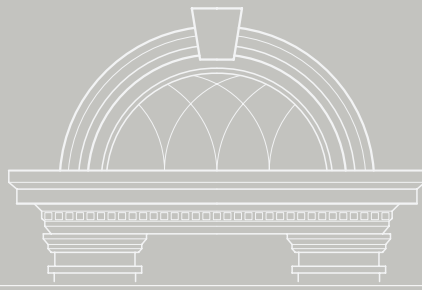

CT MOLDINGS

BACKBAND

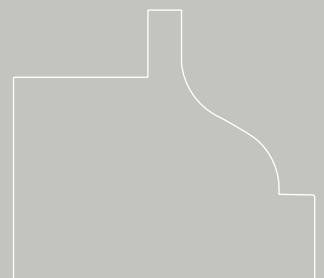
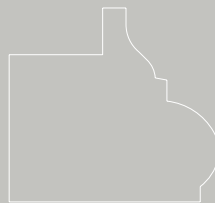
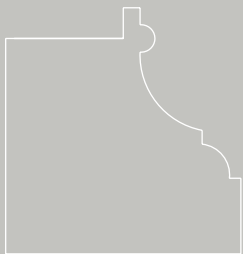
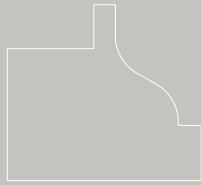
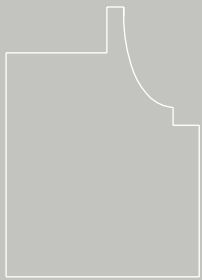

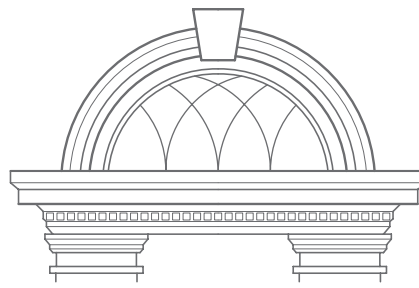

CT MOLDINGS

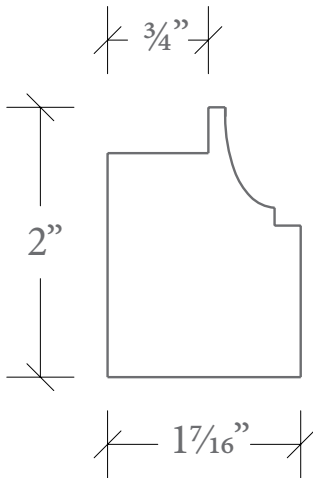

CTM | BB | 01

$\frac{3}{4}$ " x 2" x $1\frac{7}{16}$ "

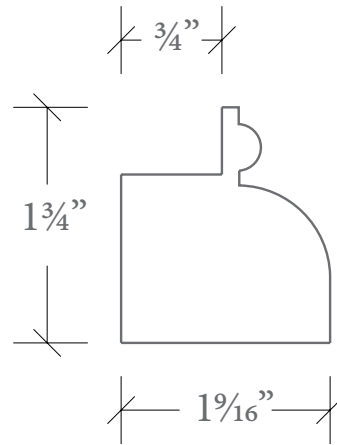

CTM | BB | 02

$\frac{3}{4}$ " x $1\frac{3}{4}$ " x $1\frac{9}{16}$ "

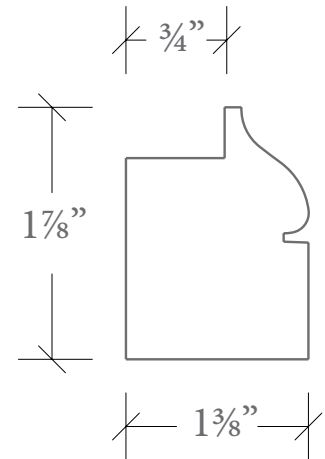

CTM | BB | 03

$\frac{3}{4}$ " x $1\frac{7}{8}$ " x $1\frac{3}{8}$ "

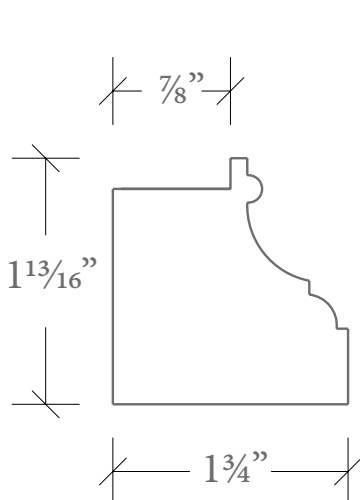

CTM | BB | 04

$\frac{7}{8}$ " x $1\frac{13}{16}$ " x $1\frac{3}{4}$ "

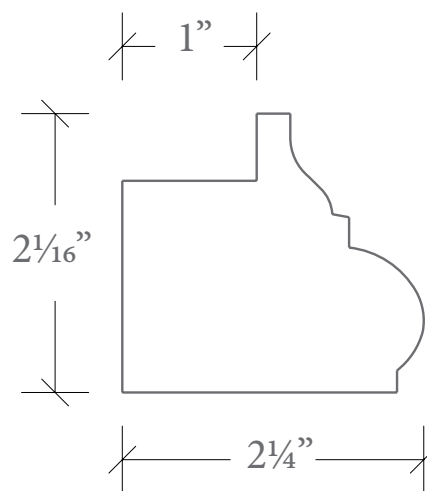

CTM | BB | 05

1" x $2\frac{1}{16}$ " x $2\frac{1}{4}$ "

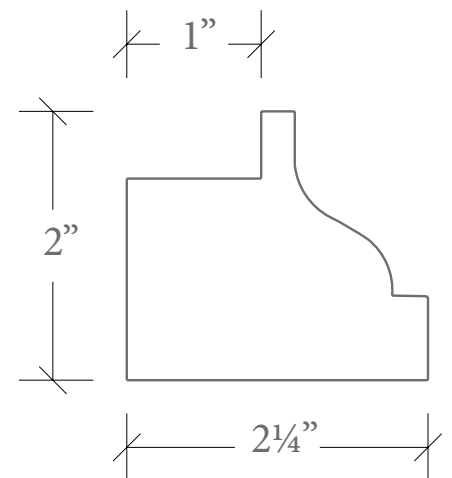

CTM | BB | 06

1" x 2" x $2\frac{1}{4}$ "

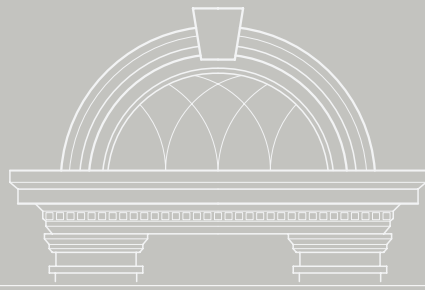

CT MOLDINGS

BASE CAP



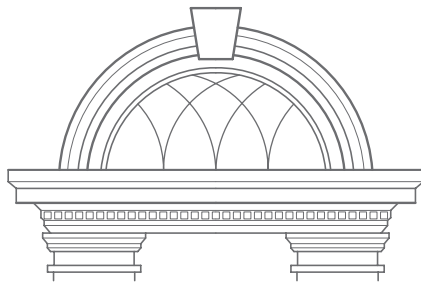

CT MOLDINGS

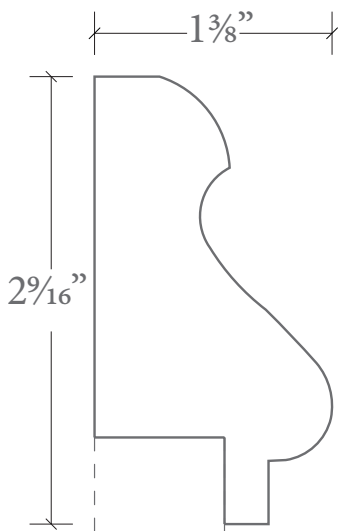

CTM | BC | 1

$2\frac{9}{16}'' \times 1\frac{3}{8}''$

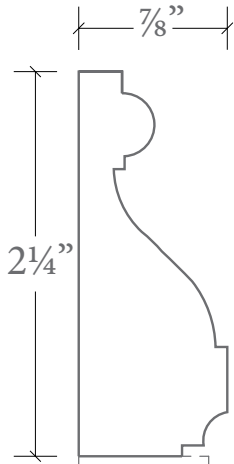

CTM | BC | 2 ●

$2\frac{1}{4}'' \times \frac{7}{8}''$

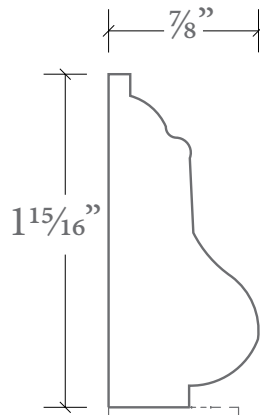

CTM | BC | 3 ●

$1\frac{15}{16}'' \times \frac{7}{8}''$

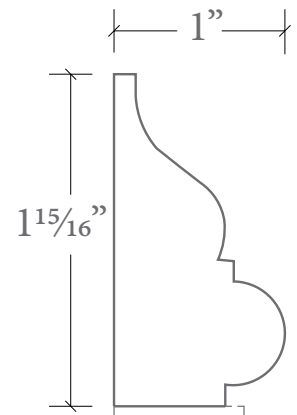

CTM | BC | 4

$1\frac{15}{16}'' \times 1''$

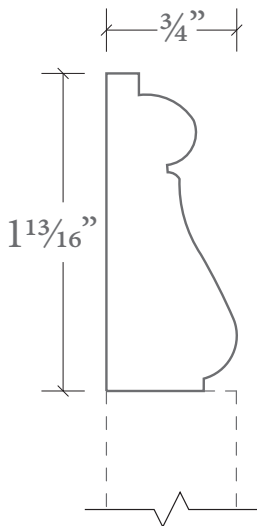

CTM | BC | 5 ●

$1\frac{13}{16}'' \times \frac{3}{4}''$

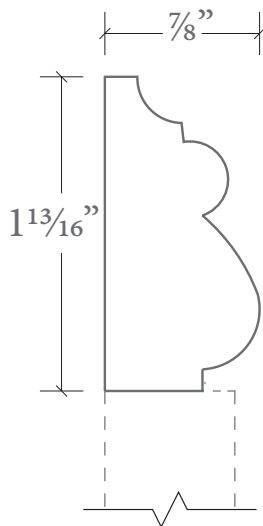

CTM | BC | 6

$1\frac{13}{16}'' \times \frac{7}{8}''$

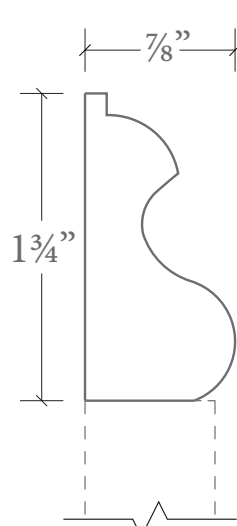

CTM | BC | 7 ●

$1\frac{3}{4}'' \times \frac{7}{8}''$

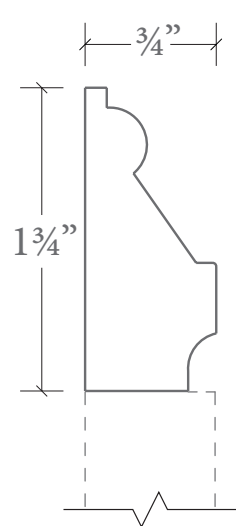

CTM | BC | 8 ●

$1\frac{3}{4}'' \times \frac{3}{4}''$

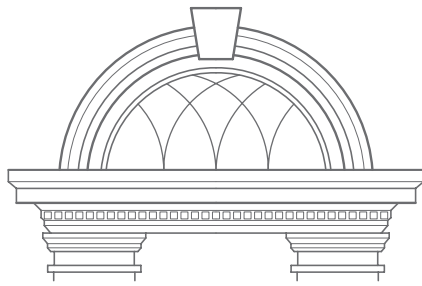

CT MOLDINGS

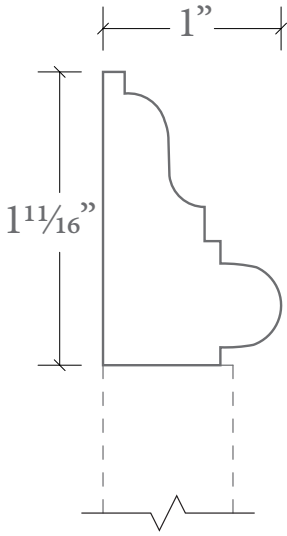

CTM | BC | 9

$1\frac{11}{16} \times 1$ "

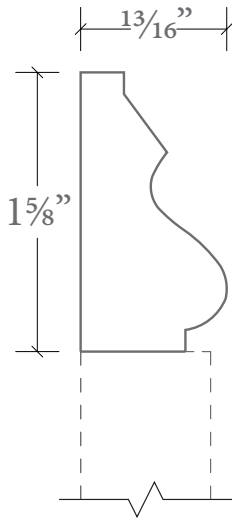

CTM | BC | 10

$1\frac{5}{8} \times \frac{13}{16}$ "

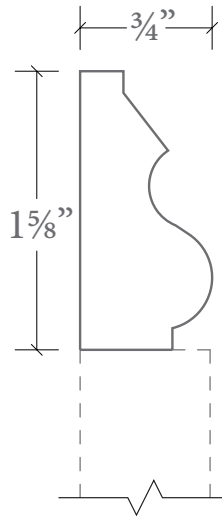

CTM | BC | 11 ●

$1\frac{5}{8} \times \frac{3}{4}$ "

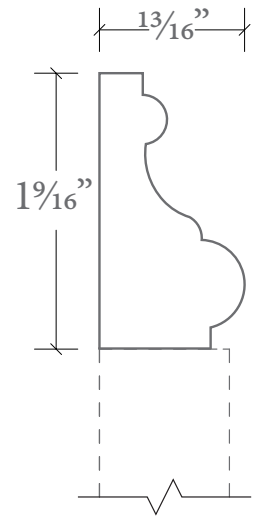

CTM | BC | 12 ●

$1\frac{9}{16} \times \frac{13}{16}$ "

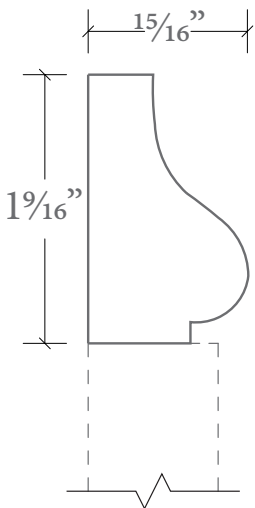

CTM | BC | 13

$1\frac{9}{16} \times \frac{15}{16}$ "

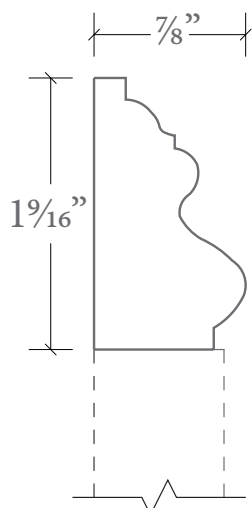

CTM | BC | 14

$1\frac{9}{16} \times \frac{7}{8}$ "

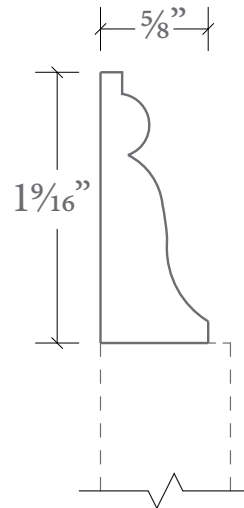

CTM | BC | 15

$1\frac{9}{16} \times \frac{5}{8}$ "

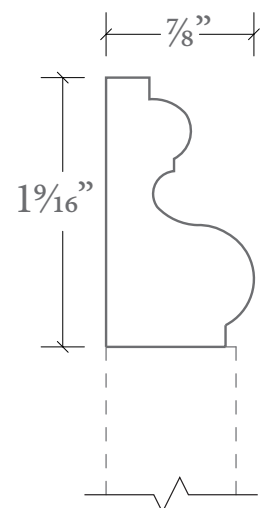

CTM | BC | 16

$1\frac{9}{16} \times \frac{7}{8}$ "

● Molding can be curved

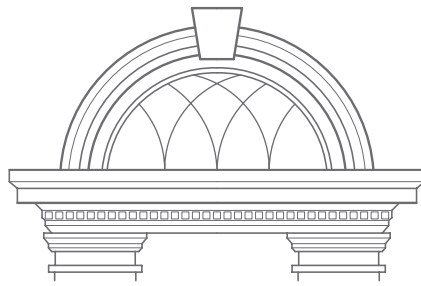

CT MOLDINGS

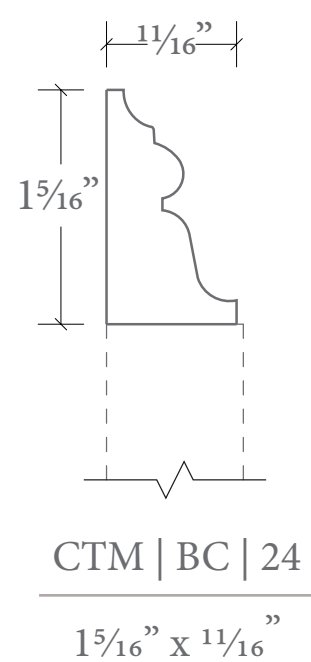
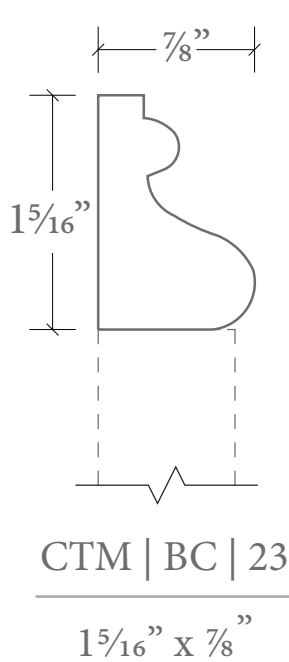
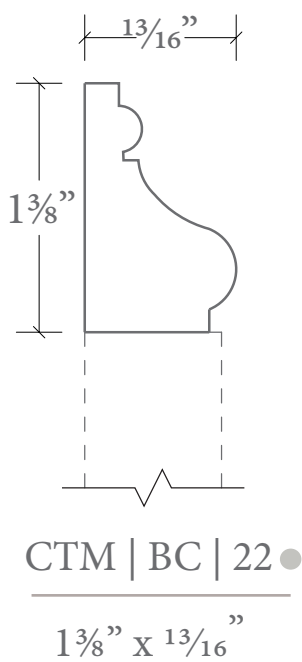
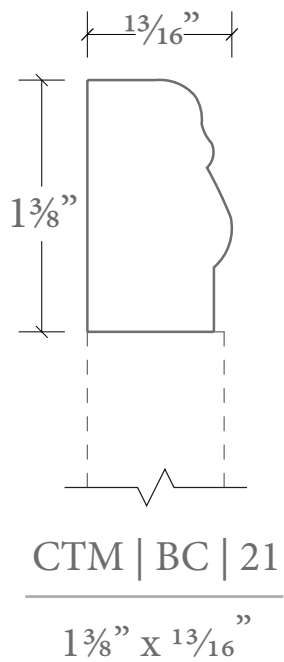
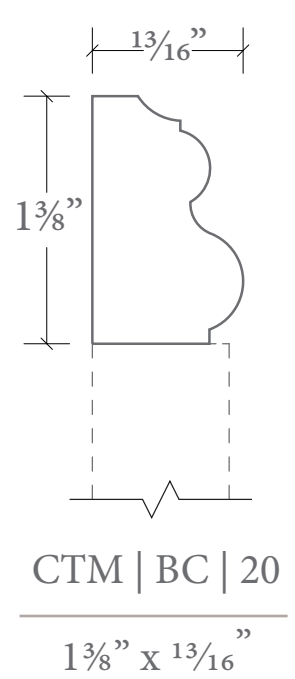
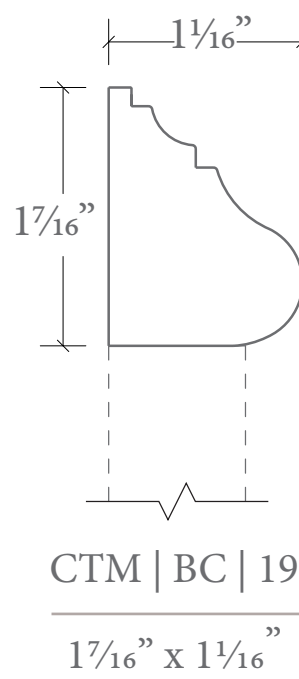
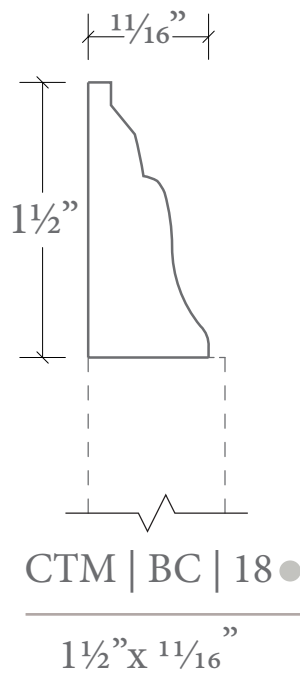
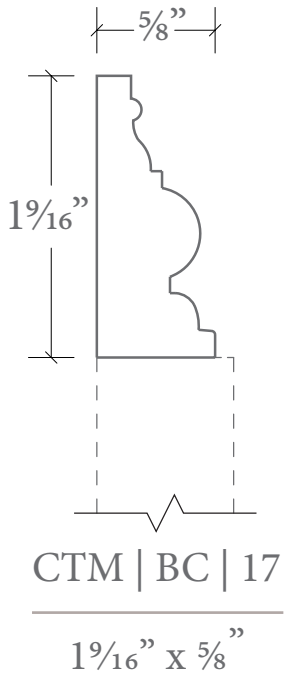

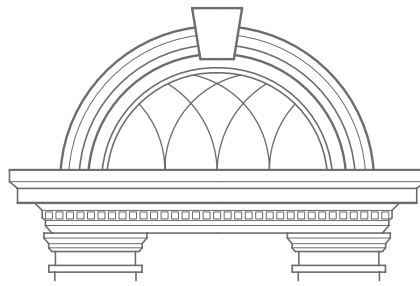

CT MOLDINGS

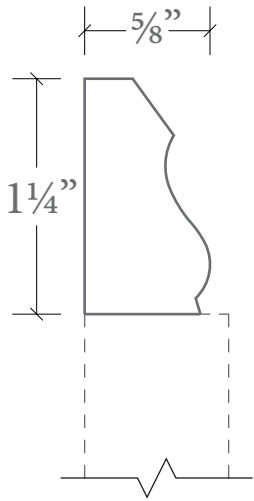

CTM | BC | 25 ●

1 1/4 x 5/8"

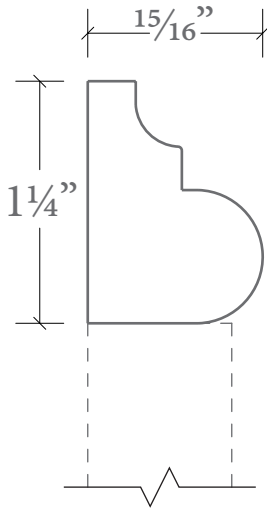

CTM | BC | 26 ●

1 1/4 x 15/16"

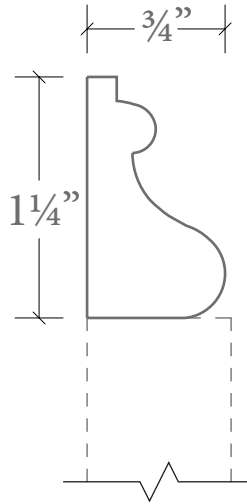

CTM | BC | 27

1 1/4 x 3/4"

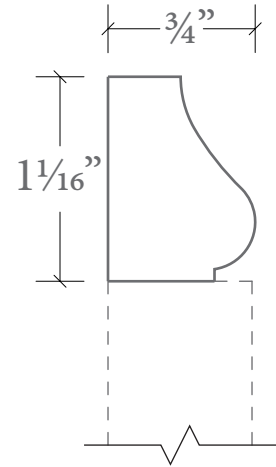

CTM | BC | 28 ●

1 1/16 x 3/4"

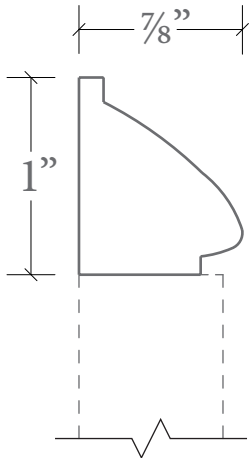

CTM | BC | 29

1 x 7/8"

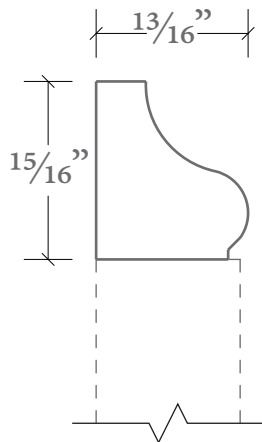

CTM | BC | 30

15/16 x 13/16"

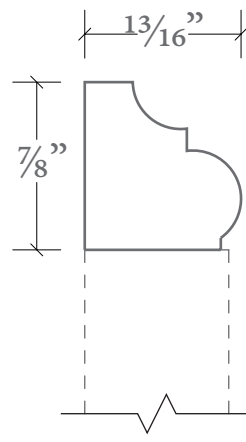

CTM | BC | 31 ●

7/8 x 13/16"

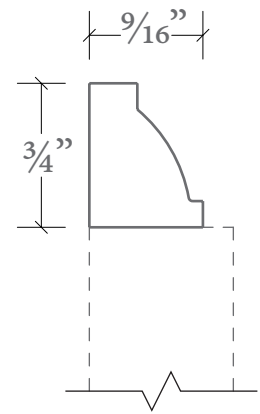

CTM | BC | 32

3/4 x 9/16"

● Molding can be curved



BEADED EDGE

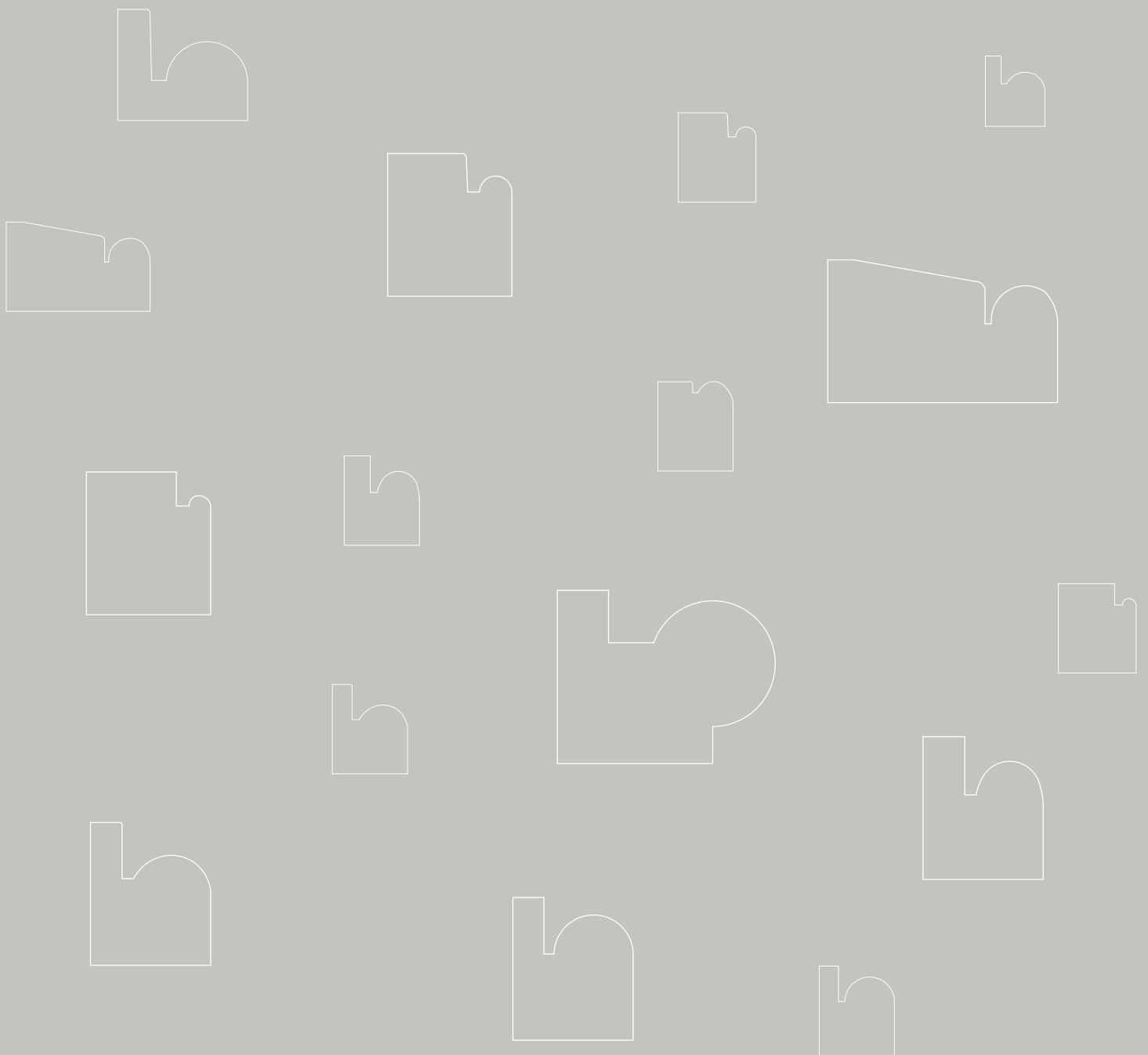

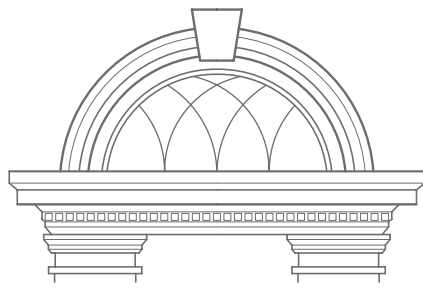

CT MOLDINGS

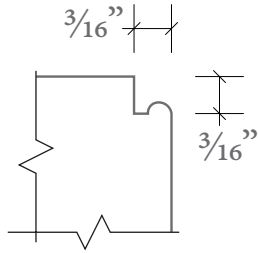

CTM | BE | 1

$\frac{3}{16}$ " X $\frac{3}{16}$ "

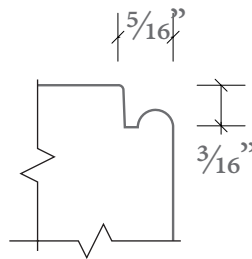

CTM | BE | 2

$\frac{5}{16}$ " X $\frac{3}{16}$ "

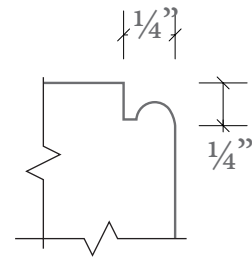

CTM | BE | 3

$\frac{1}{4}$ " X $\frac{1}{4}$ "

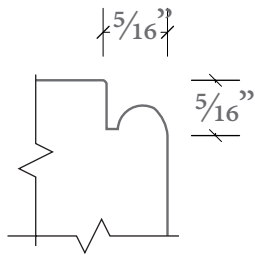

CTM | BE | 4

$\frac{5}{16}$ " X $\frac{5}{16}$ "

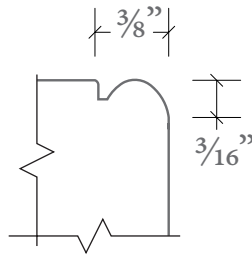

CTM | BE | 5

$\frac{3}{8}$ " X $\frac{3}{16}$ "

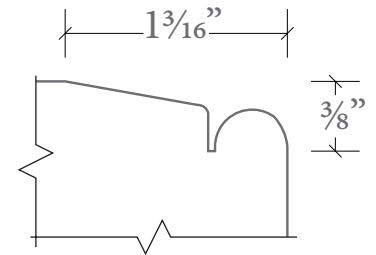

CTM | BE | 6

$1\frac{3}{16}$ " X $\frac{3}{8}$ "

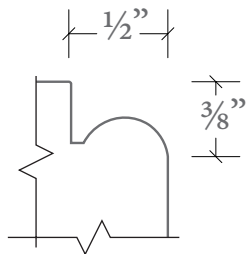

CTM | BE | 7

$\frac{1}{2}$ " X $\frac{3}{8}$ "

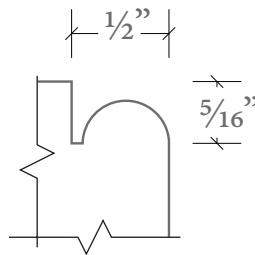

CTM | BE | 8

$\frac{1}{2}$ " X $\frac{5}{16}$ "

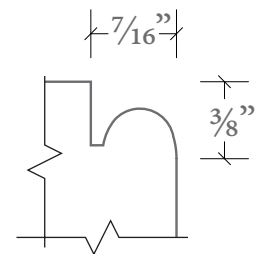

CTM | BE | 9

$\frac{7}{16}$ " X $\frac{3}{8}$ "

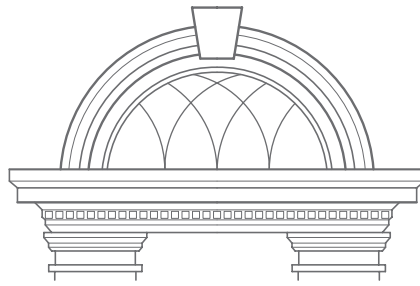

CT MOLDINGS

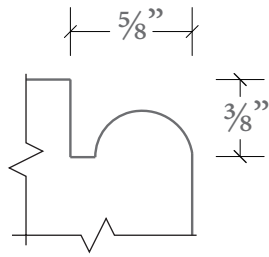

CTM | BE | 10

$\frac{5}{8} \times \frac{3}{8}$ "

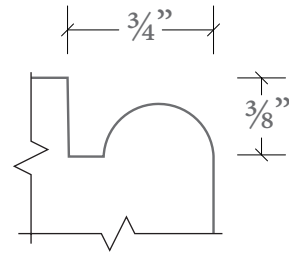

CTM | BE | 11

$\frac{3}{4} \times \frac{3}{8}$ "

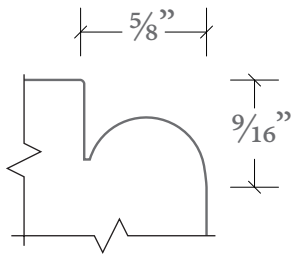

CTM | BE | 12 ●

$\frac{5}{8} \times \frac{9}{16}$ "

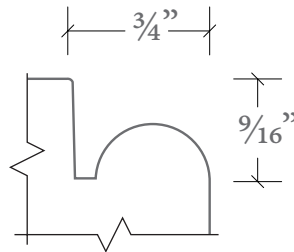

CTM | BE | 13 ●

$\frac{3}{4} \times \frac{9}{16}$ "

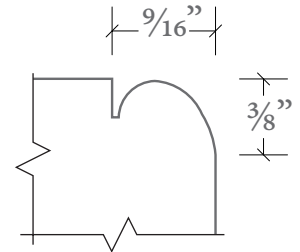

CTM | BE | 14

$\frac{9}{16} \times \frac{3}{8}$ "

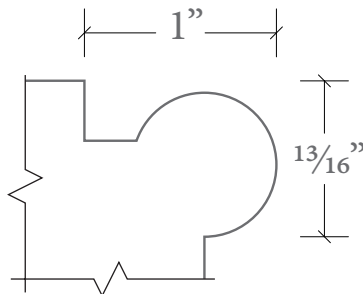

CTM | BE | 15 ●

$1 \times \frac{13}{16}$ "

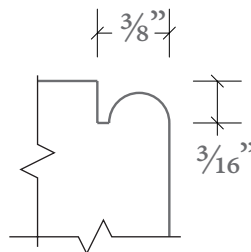

CTM | BE | 16 ●

$\frac{3}{8} \times \frac{3}{16}$ "

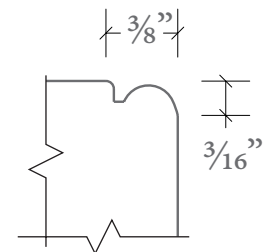

CTM | BE | 17

$\frac{3}{8} \times \frac{3}{16}$ "

● Molding can be curved

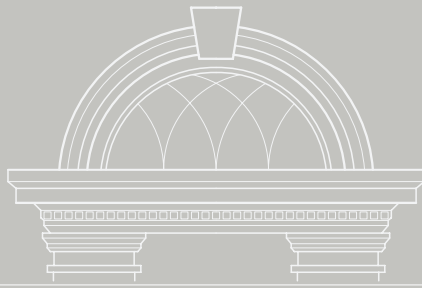

CT MOLDINGS

CAP MOLDING

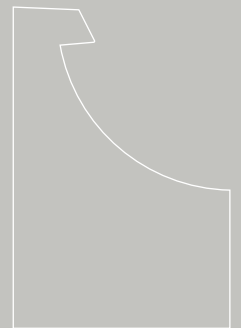
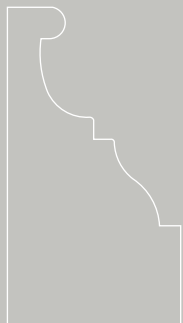
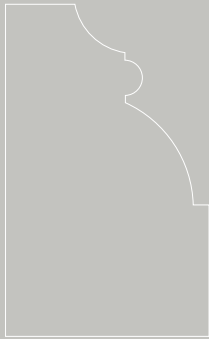
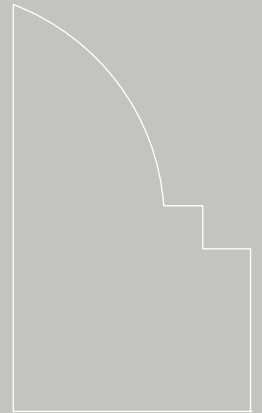
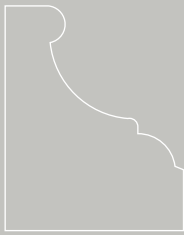

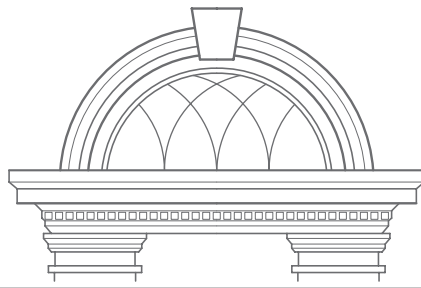

CT MOLDINGS

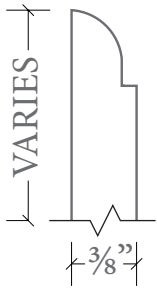

CTM | CM | 1

 VARIES x 3/8"

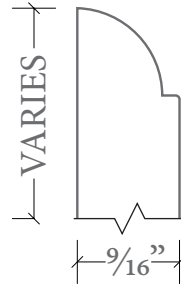

CTM | CM | 2 ●

 VARIES x 9/16"



CTM | CM | 3

 VARIES x 1/2"

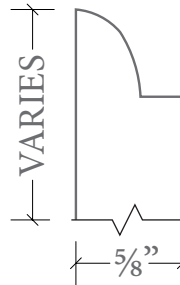

CTM | CM | 4 ●

 VARIES x 5/8"

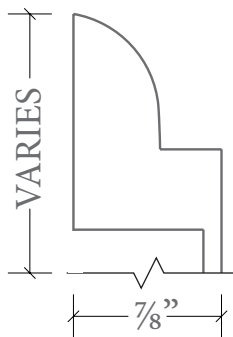

CTM | CM | 5

 VARIES x 7/8"

■ 5/8" | 3/4"

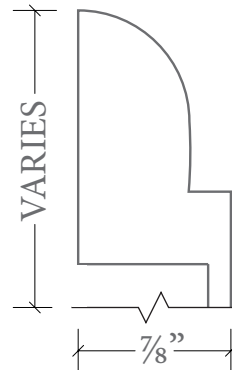

CTM | CM | 6 ●

 VARIES x 7/8"

■ 5/8" | 3/4"

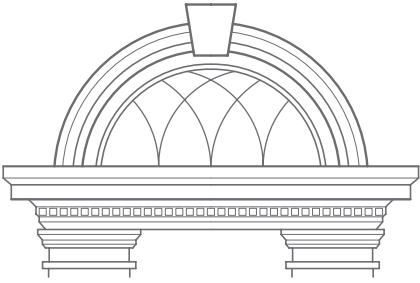

CT MOLDINGS

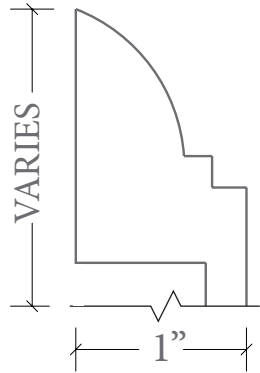

CTM | CM | 7

VARIES x 1"

■ 5/8" | 3/4"

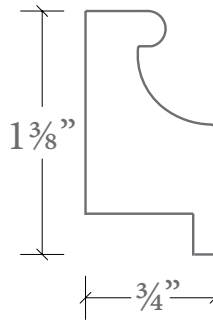

CTM | CM | 8

1 3/8" x 3/4"

■ 5/8"

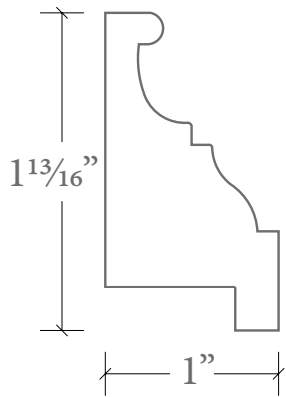

CTM | CM | 9

1 13/16 x 1"

■ 5/8" | 3/4"

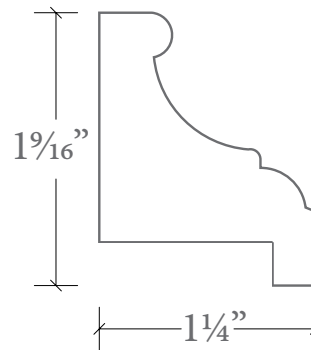

CTM | CM | 10 ●

1 9/16 x 1 1/4"

■ 5/8" | 3/4" | 1"

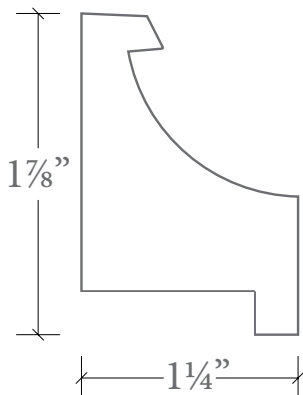

CTM | CM | 11

1 7/8 x 1 1/4"

■ 5/8" | 3/4" | 1"

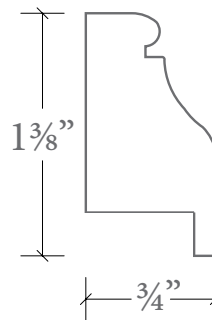

CTM | CM | 12

1 3/8" x 3/4"

■ 5/8"

● Molding can be curved

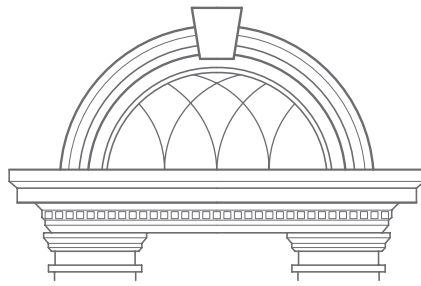

CT MOLDINGS

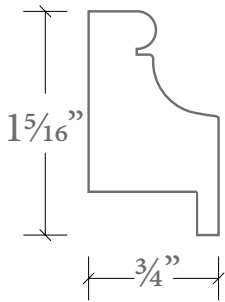

CTM | CM | 13 ●

$1\frac{5}{16} \times \frac{3}{4}$

■ $\frac{5}{8}$

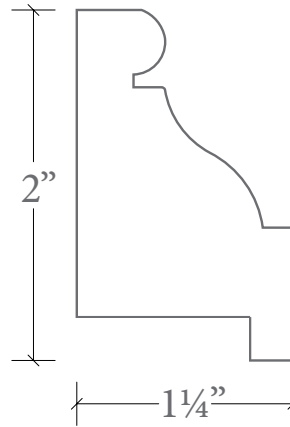

CTM | CM | 14 ●

$2 \times 1\frac{1}{4}$

■ $\frac{5}{8} \mid \frac{3}{4} \mid 1$

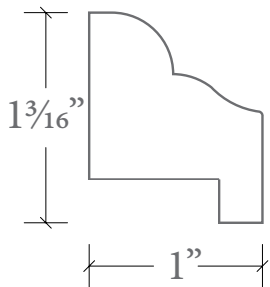

CTM | CM | 15

$1\frac{3}{16} \times 1$

■ $\frac{5}{8} \mid \frac{3}{4}$

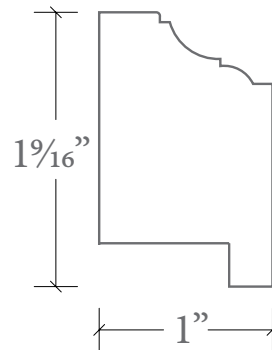

CTM | CM | 16

$1\frac{9}{16} \times 1$

■ $\frac{5}{8} \mid \frac{3}{4}$

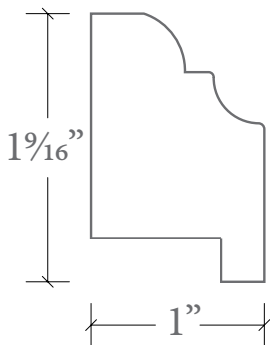

CTM | CM | 17

$1\frac{9}{16} \times 1$

■ $\frac{5}{8} \mid \frac{3}{4}$

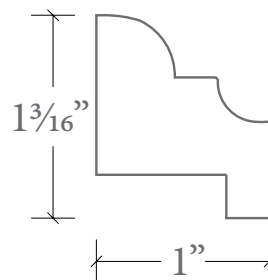

CTM | CM | 18

$1\frac{3}{16} \times 1$

■ $\frac{5}{8} \mid \frac{3}{4}$

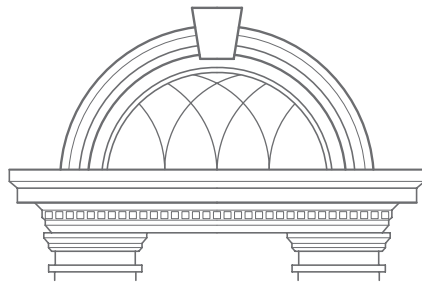

CT MOLDINGS

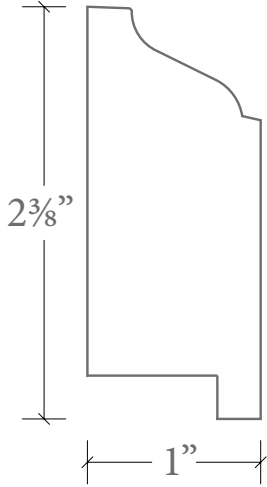

CTM | CM | 19

$2\frac{3}{8}'' \times 1''$

■ $\frac{5}{8}'' \mid \frac{3}{4}''$

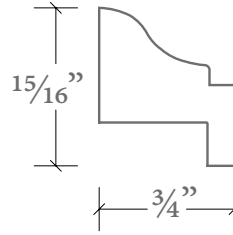

CTM | CM | 20

$1\frac{5}{16}'' \times \frac{3}{4}''$

■ $\frac{5}{8}''$

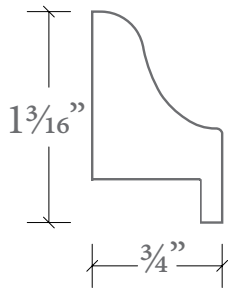

CTM | CM | 21

$1\frac{3}{16}'' \times \frac{3}{4}''$

■ $\frac{5}{8}''$

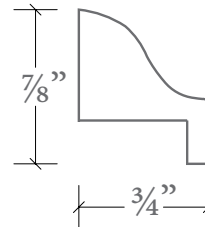

CTM | CM | 22

$\frac{7}{8}'' \times \frac{3}{4}''$

■ $\frac{5}{8}''$

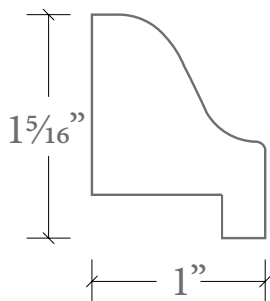

CTM | CM | 23 ●

$1\frac{5}{16}'' \times 1''$

■ $\frac{5}{8}'' \mid \frac{3}{4}''$

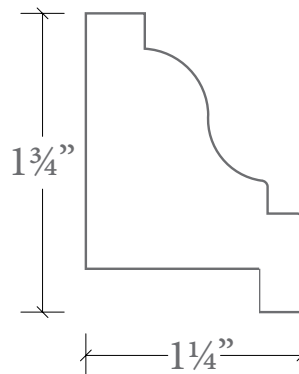

CTM | CM | 24

$1\frac{3}{4}'' \times 1\frac{1}{4}''$

■ $\frac{5}{8}'' \mid \frac{3}{4}'' \mid 1''$

● Molding can be curved

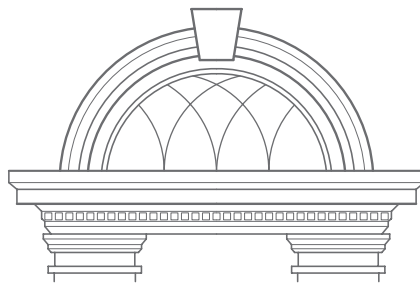

CT MOLDINGS

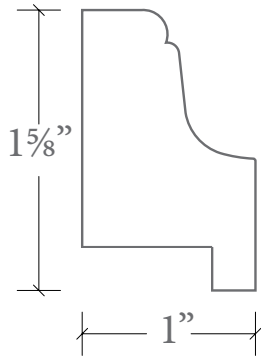

CTM | CM | 25

1 5/8" x 1"

■ 5/8" | 3/4"

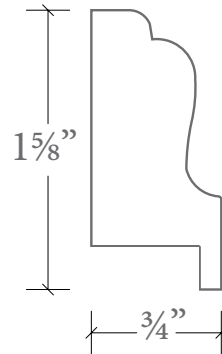

CTM | CM | 26

1 5/8" x 3/4"

■ 5/8"

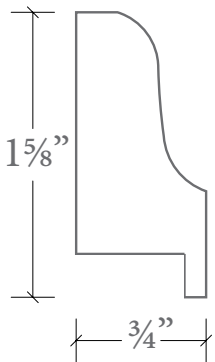

CTM | CM | 27

1 5/8" x 3/4"

■ 5/8"

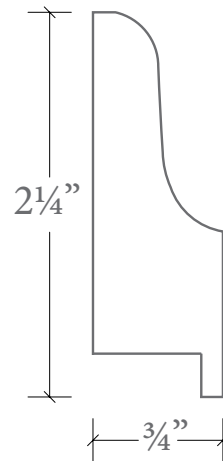

CTM | CM | 28

2 1/4" x 3/4"

■ 5/8"

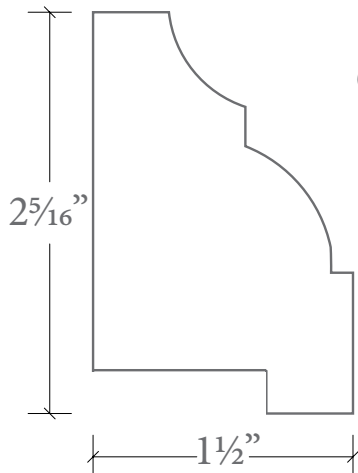

CTM | CM | 29

2 5/16" x 1 1/2"

■ 5/8" | 3/4" | 1"

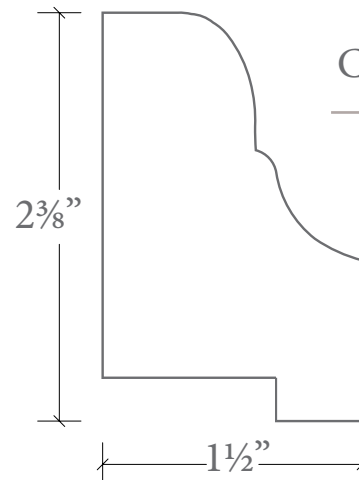

CTM | CM | 30

2 3/8" x 1 1/2"

■ 5/8" | 3/4" | 1"

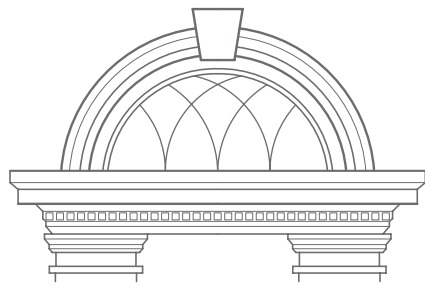

CT MOLDINGS

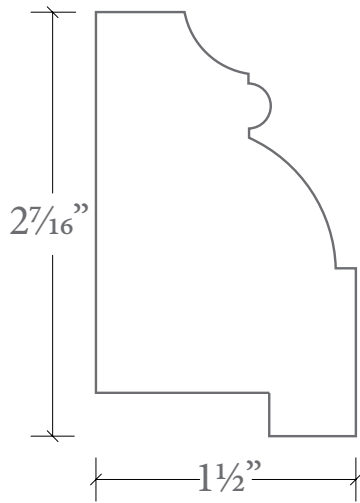

CTM | CM | 31 ●

$2\frac{7}{16} \times 1\frac{1}{2}$ "

■ $\frac{5}{8}$ " | $\frac{3}{4}$ " | 1"

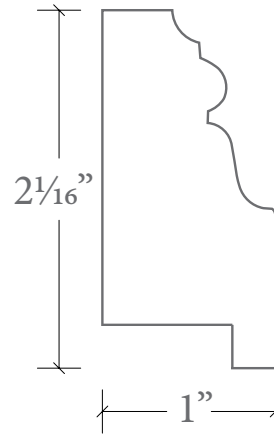

CTM | CM | 32

$2\frac{1}{16} \times 1$ "

■ $\frac{5}{8}$ " | $\frac{3}{4}$ "

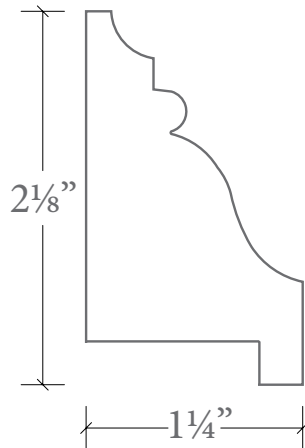

CTM | CM | 33

$2\frac{1}{8} \times 1\frac{1}{4}$ "

■ $\frac{5}{8}$ " | $\frac{3}{4}$ " | 1"



CTM | CM | 34

$3\frac{5}{16} \times 1\frac{1}{2}$ "

■ $\frac{5}{8}$ " | $\frac{3}{4}$ " | 1"

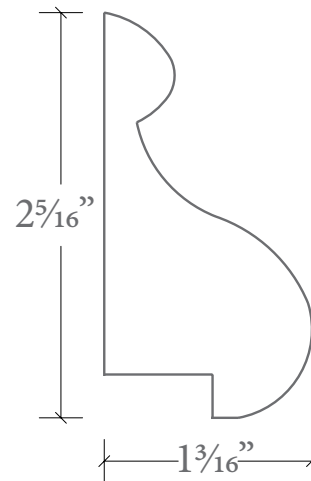

CTM | CM | 35

$2\frac{5}{16} \times 1\frac{3}{16}$ "

■ $\frac{5}{8}$ "

● Molding can be curved

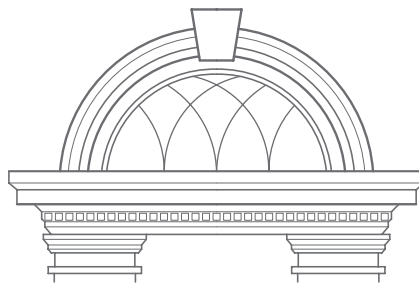

CT MOLDINGS

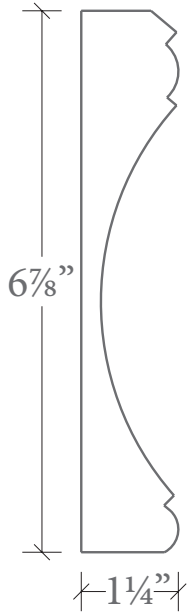

CTM | CS | 01

 6 7/8" x 1 1/4"

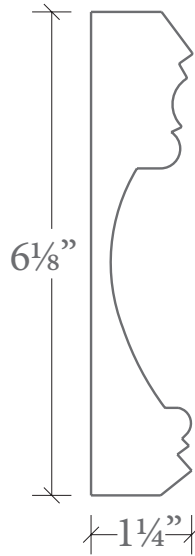

CTM | CS | 02

 6 1/8" x 1 1/4"

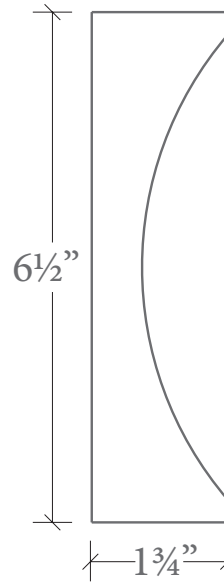

CTM | CS | 03

 6 1/2" x 1 3/4"

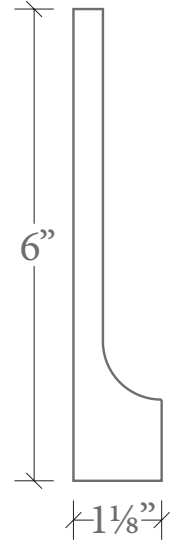

CTM | CS | 04

 6" x 1 1/8"

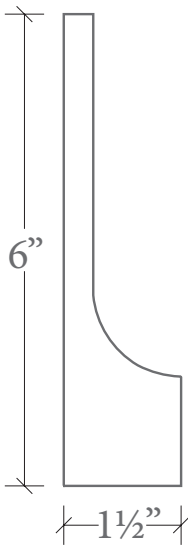

CTM | CS | 05

 6" x 1 1/2"

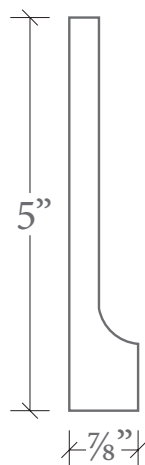

CTM | CS | 06

 5" x 7/8"

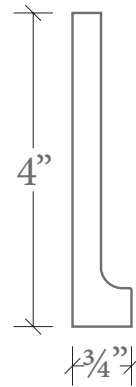

CTM | CS | 07

 4" x 3/4"

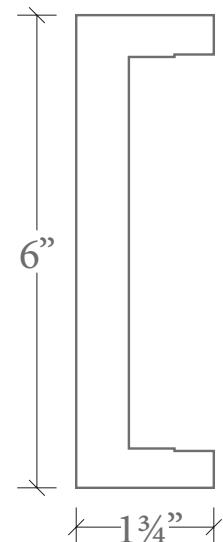

CTM | CS | 08

 6" x 1 3/4"

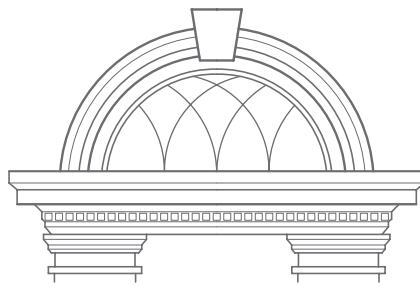

CT MOLDINGS

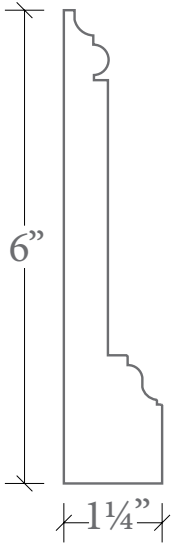

CTM | CS | 09

6" x 1 1/4"

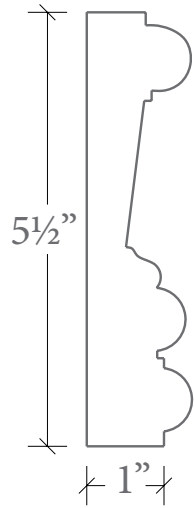

CTM | CS | 10 ●

5 1/2" x 1"

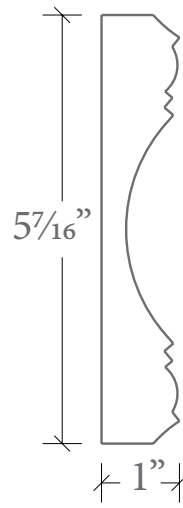

CTM | CS | 11

5 7/16" x 1"

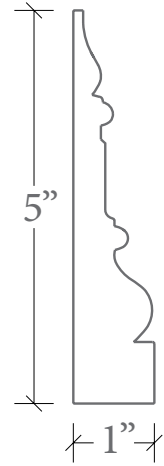

CTM | CS | 12 ●

5" x 1"

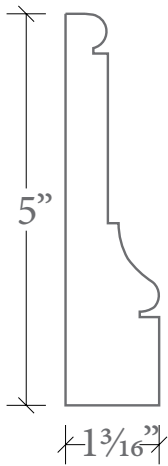

CTM | CS | 13

5" x 1 3/16"

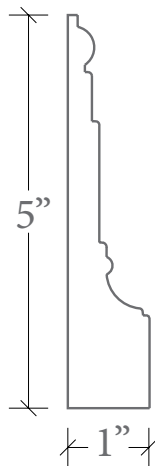

CTM | CS | 14

5" x 1"

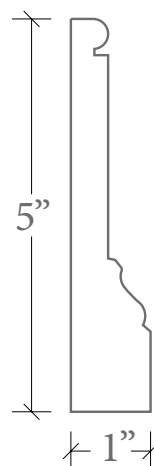

CTM | CS | 15

5" x 1"

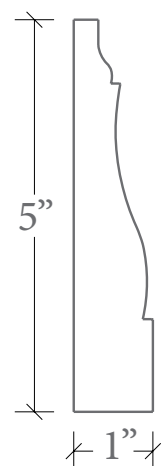

CTM | CS | 16

5" x 1"

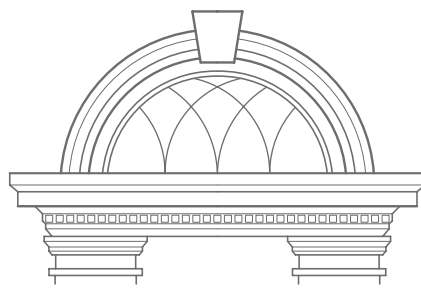

CT MOLDINGS

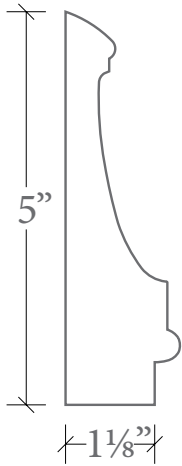

CTM | CS | 17

5" x 1 1/8"

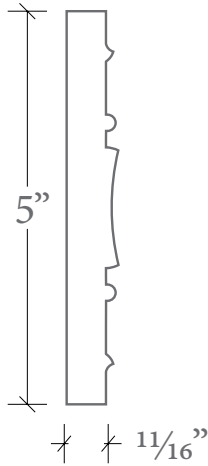

CTM | CS | 18

5" x 1 1/16"

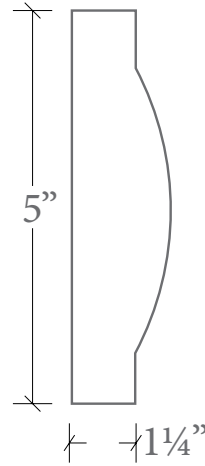

CTM | CS | 19

5" x 1 1/4"

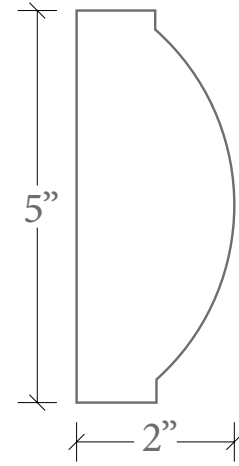

CTM | CS | 20

5" x 2"

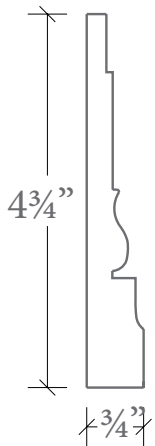

CTM | CS | 21 ●

4 3/4" x 3/4"

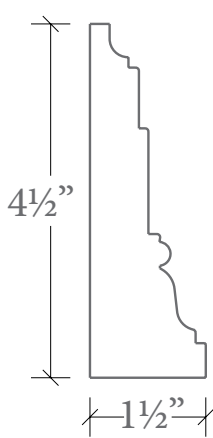

CTM | CS | 22

4 1/2" x 1 1/2"

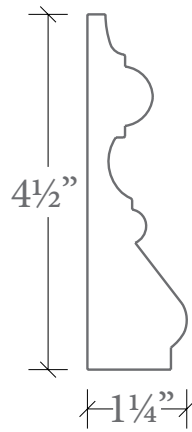

CTM | CS | 23

4 1/2" x 1 1/4"

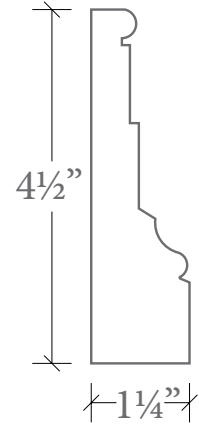

CTM | CS | 24 ●

4 1/2" x 1 1/4"

● Molding can be curved

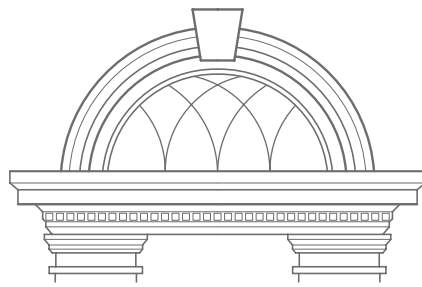

CT MOLDINGS

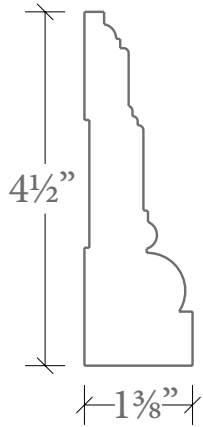

CTM | CS | 25 ●

$4\frac{1}{2}'' \times 1\frac{3}{8}''$

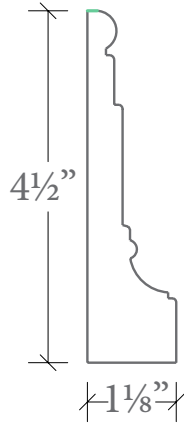

CTM | CS | 26 ●

$4\frac{1}{2}'' \times 1\frac{1}{8}''$

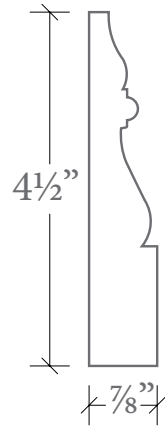

CTM | CS | 27

$4\frac{1}{2}'' \times \frac{7}{8}''$

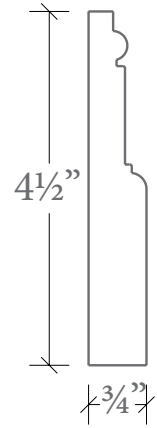

CTM | CS | 28 ●

$4\frac{1}{2}'' \times \frac{3}{4}''$

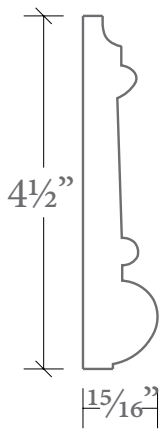

CTM | CS | 29

$4\frac{1}{2}'' \times \frac{15}{16}''$

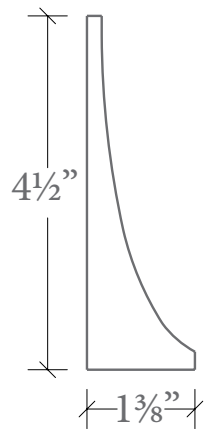

CTM | CS | 30

$4\frac{1}{2}'' \times 1\frac{3}{8}''$

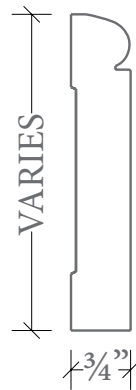

CTM | CS | 31

VARIES x $\frac{3}{4}''$

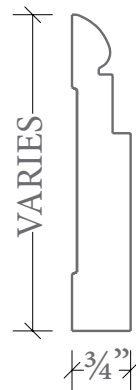

CTM | CS | 32 ●

VARIES x $\frac{3}{4}''$

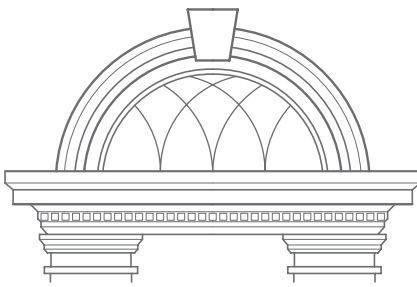

CT MOLDINGS

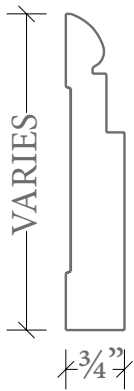

CTM | CS | 33 ●
VARIES x 3/4"

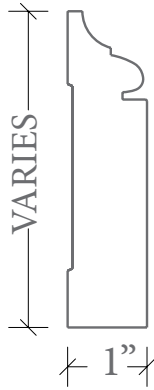

CTM | CS | 34
VARIES x 1"



CTM | CS | 35 ●
VARIES x 1"

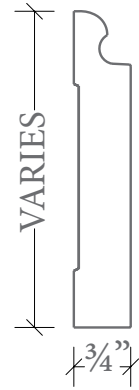

CTM | CS | 36 ●
VARIES x 3/4"

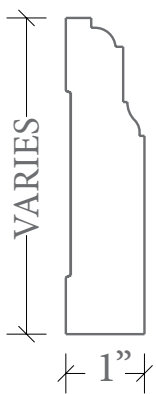

CTM | CS | 37
VARIES x 1"



CTM | CS | 38
VARIES x 3/4"

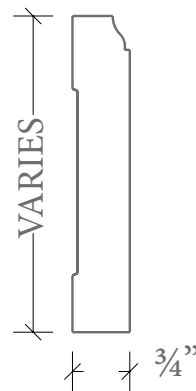

CTM | CS | 39
VARIES x 3/4"

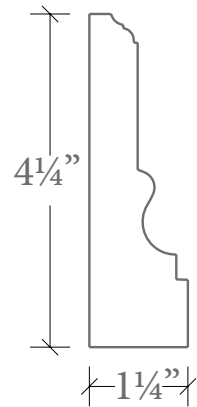

CTM | CS | 40
4 1/4" x 1 1/4"

● Molding can be curved

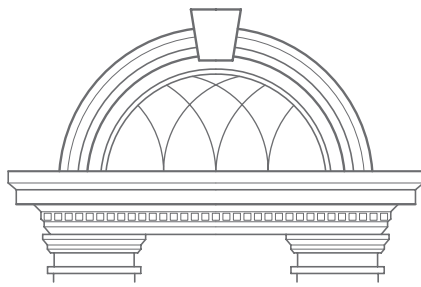

CT MOLDINGS

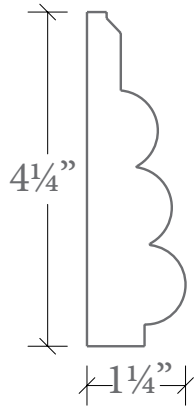

CTM | CS | 41

4 1/4" x 1 1/4"



CTM | CS | 42

4 3/16" x 3/4"

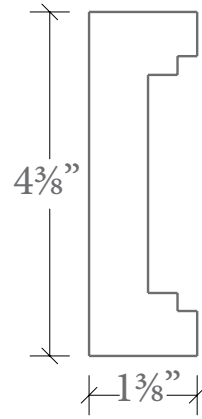

CTM | CS | 43 ●

4 3/8" x 1 3/8"

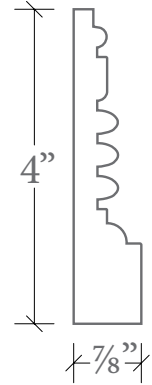

CTM | CS | 44

4" x 7/8"

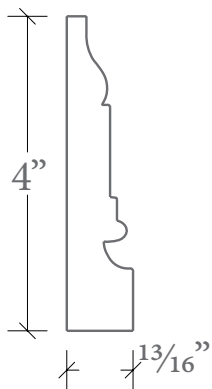

CTM | CS | 45

4" x 1 3/16"

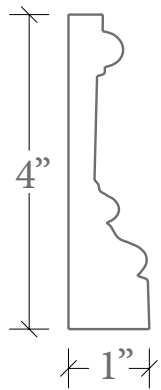

CTM | CS | 46

4" x 1"

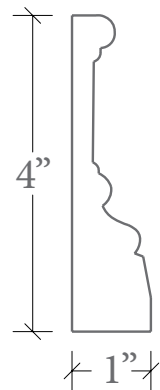

CTM | CS | 47

3" x 1"

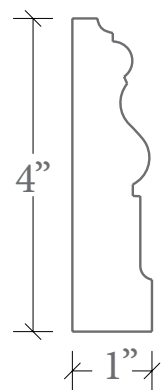

CTM | CS | 48 ●

4" x 1"

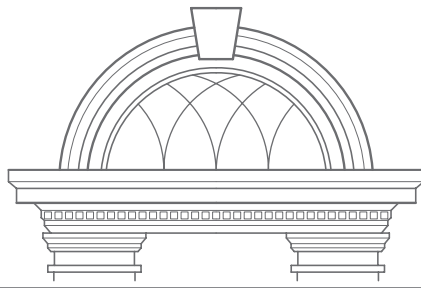

CT MOLDINGS

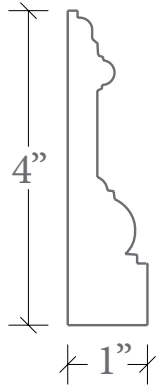

CTM | CS | 49

$4'' \times 1''$

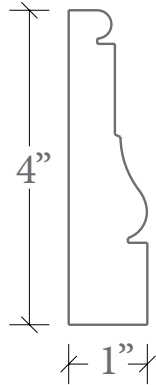

CTM | CS | 50

$4'' \times 1''$

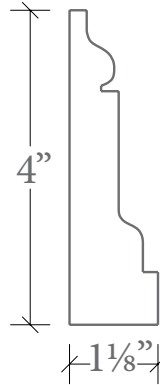

CTM | CS | 51 ●

$4'' \times 1\frac{1}{8}''$

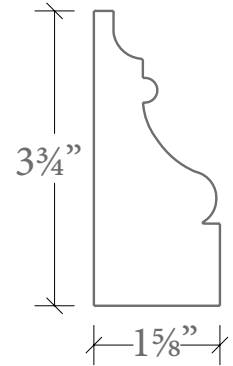

CTM | CS | 52

$3\frac{3}{4}'' \times 1\frac{5}{8}''$

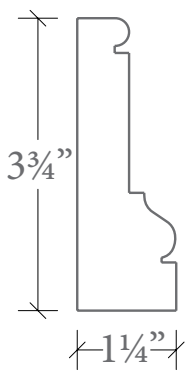

CTM | CS | 53 ●

$3\frac{3}{4}'' \times 1\frac{1}{4}''$

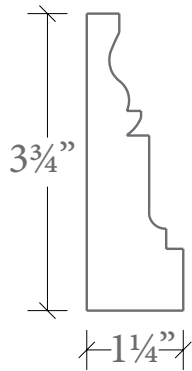

CTM | CS | 54 ●

$3\frac{3}{4}'' \times 1\frac{1}{4}''$

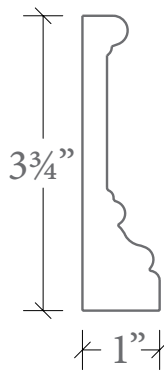

CTM | CS | 55

$3\frac{3}{4}'' \times 1''$

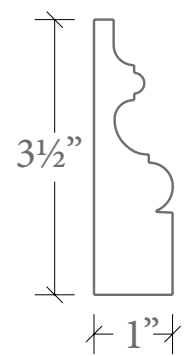

CTM | CS | 56

$3\frac{1}{2}'' \times 1''$

● Molding can be curved

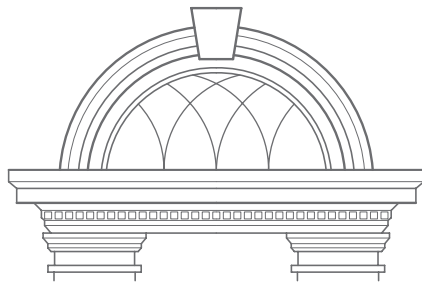

CT MOLDINGS

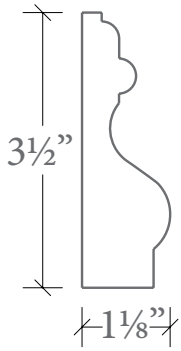

CTM | CS | 57

3 1/2" x 1 1/8"

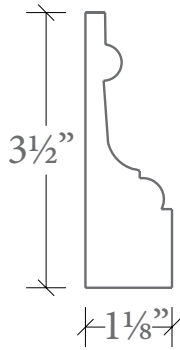

CTM | CS | 58

3 1/2" x 1 1/8"

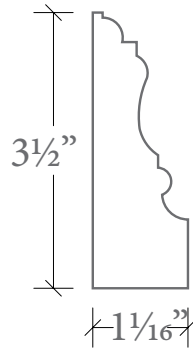

CTM | CS | 59

3 1/2" x 1 1/16"

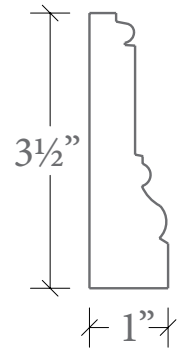

CTM | CS | 60 ●

3 1/2" x 1"



CTM | CS | 61

3 1/2" x 7/8"

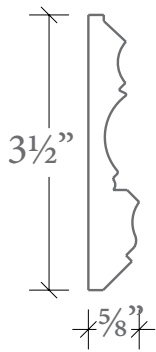

CTM | CS | 62

3 1/2" x 5/8"

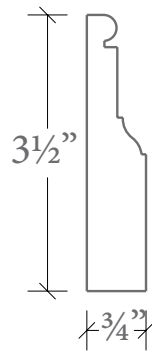

CTM | CS | 63 ●

3 1/2" x 3/4"

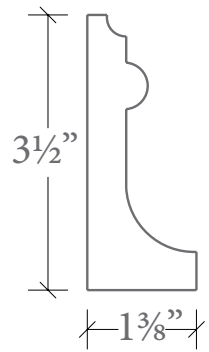

CTM | CS | 64

3 1/2" x 1 3/8"

● Molding can be curved

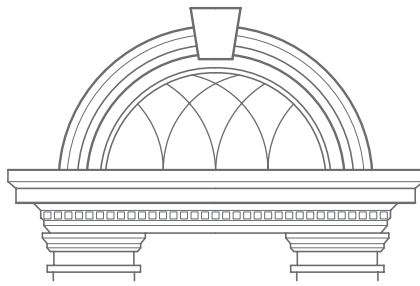

CT MOLDINGS

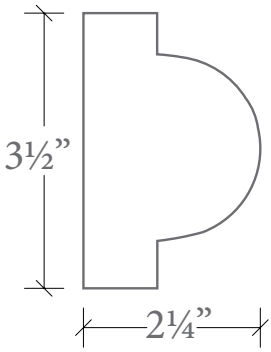

CTM | CS | 65

 3 1/2" x 2 1/4"

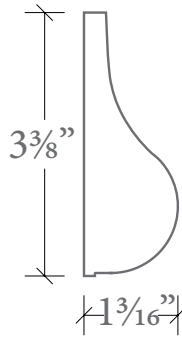

CTM | CS | 66

 3 3/8" x 1 3/16"

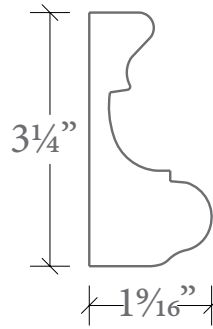

CTM | CS | 67

 3 1/4" x 1 9/16"

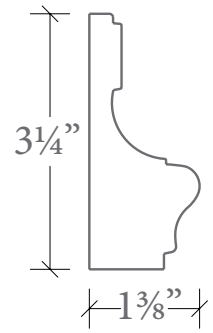

CTM | CS | 68

 3 1/4" x 1 3/8"

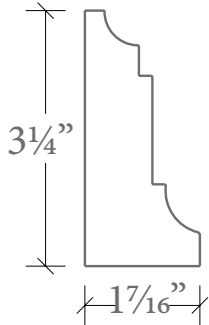

CTM | CS | 69

 3 1/4" x 1 7/16"

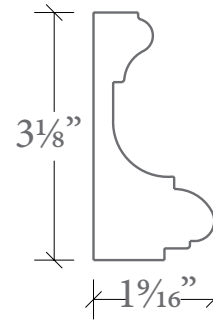

CTM | CS | 70

 3 1/8" x 1 9/16"

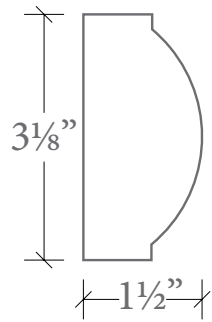

CTM | CS | 71

 3 1/8" x 1 1/2"

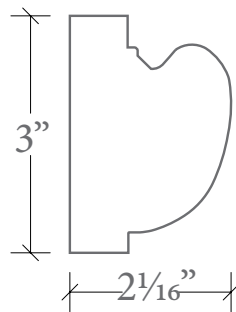

CTM | CS | 72

 3" x 2 1/16"

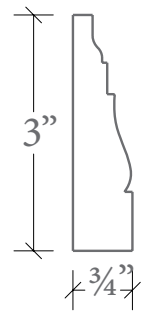

CTM | CS | 73

 3" x 3/4"

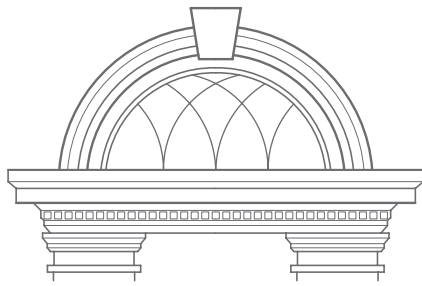

CT MOLDINGS



CTM | CS | 74

3" x 3/4"

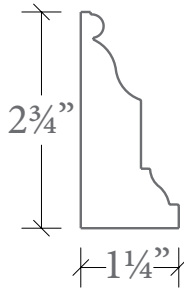

CTM | CS | 75

2 3/4" x 1 1/4"

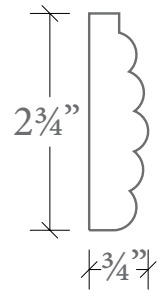

CTM | CS | 76

2 3/4" x 3/4"

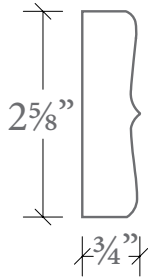

CTM | CS | 77

2 5/8" x 3/4"

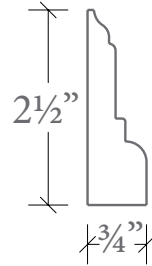

CTM | CS | 78

2 1/2" x 3/4"

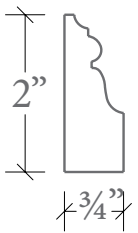

CTM | CS | 79

2" x 3/4"

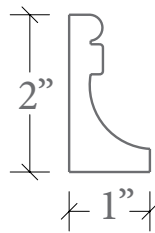

CTM | CS | 80 ●

2" x 1"

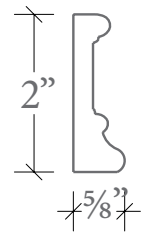

CTM | CS | 81 ●

2" x 5/8"

● Molding can be curved



CT MOLDINGS

CHAIR RAIL



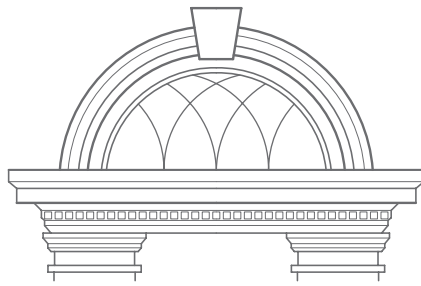

CT MOLDINGS

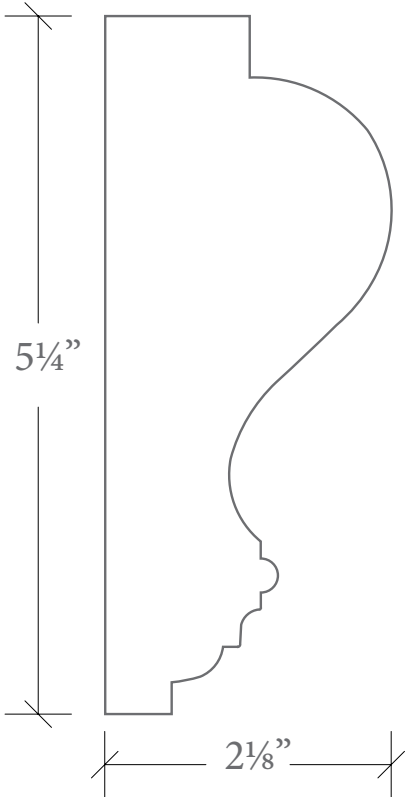

CTM | CH | 01

5 1/4" x 2 1/8"

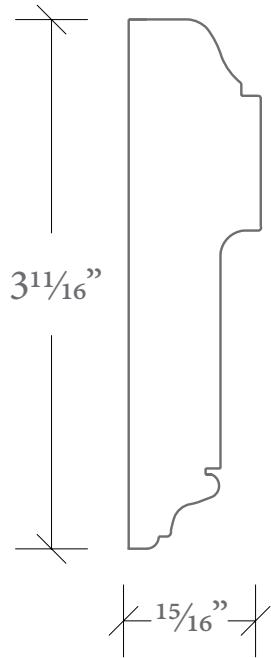

CTM | CH | 02 ●

3 11/16" x 1 5/16"

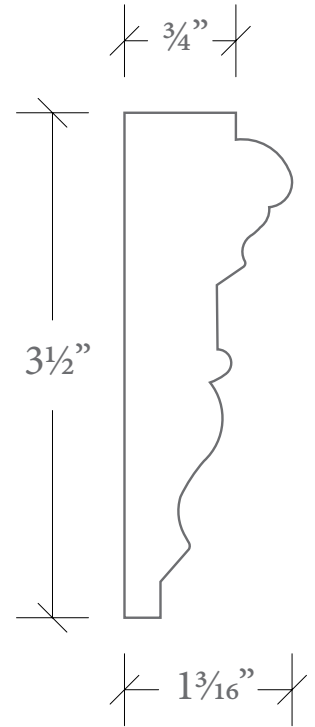

CTM | CH | 03

3/4" x 3 1/2" x 1 3/16"

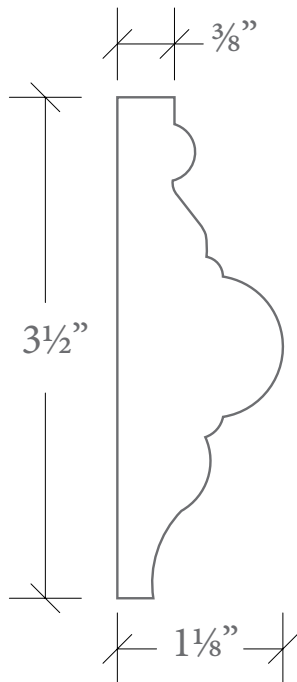

CTM | CH | 04

3 1/2" x 1 1/8"



CTM | CH | 05

3 1/4" x 3/4"

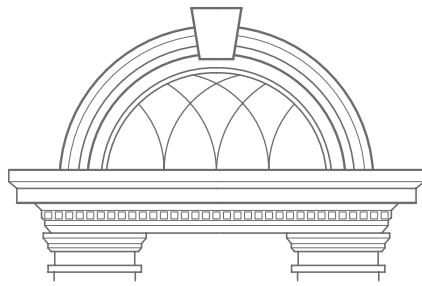

CT MOLDINGS

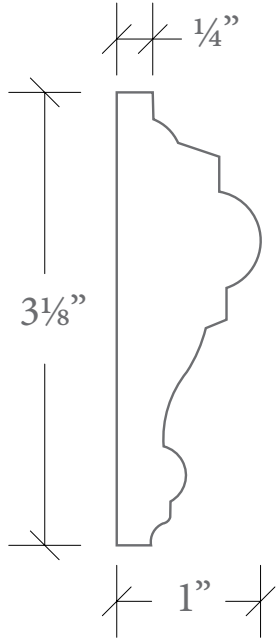

CTM | CH | 06

1/4" x 3 1/8" x 1"

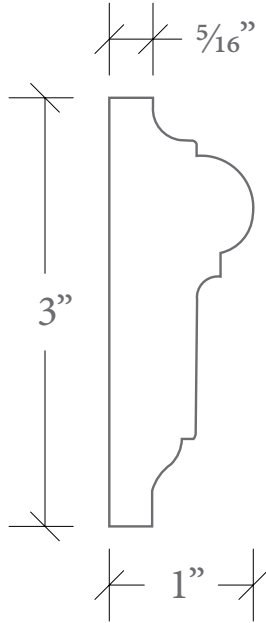

CTM | CH | 07

5/16" x 3" x 1"

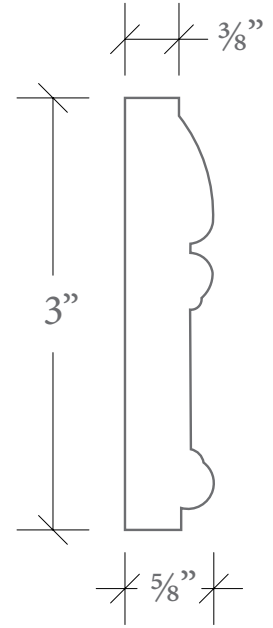

CTM | CH | 08 ●

3/8" x 3" x 5/8"

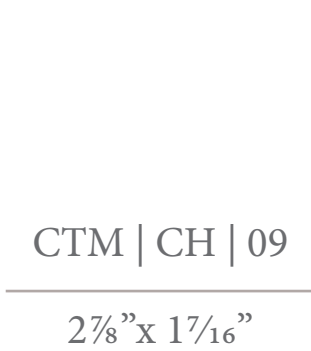

CTM | CH | 09

2 7/8" x 1 7/16"

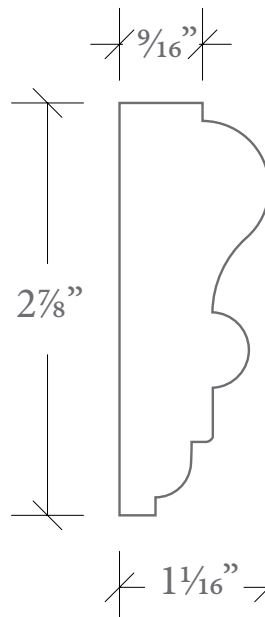

CTM | CH | 10

9/16" x 2 7/8" x 1 1/16"

● Molding can be curved

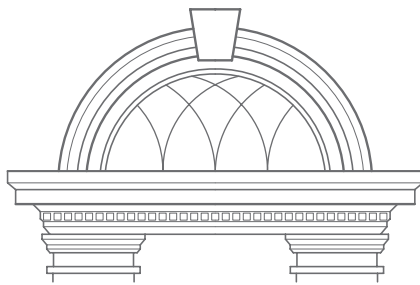

CT MOLDINGS

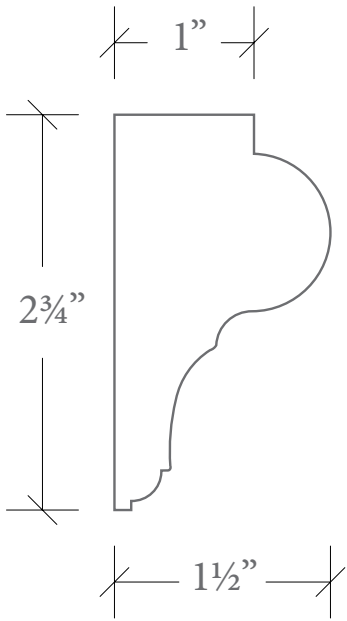

CTM | CH | 11

1" x 2 3/4" x 1 1/2"

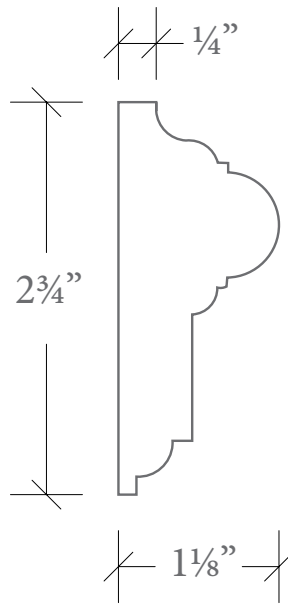

CTM | CH | 12

1/4" x 2 3/4" x 1 1/8"

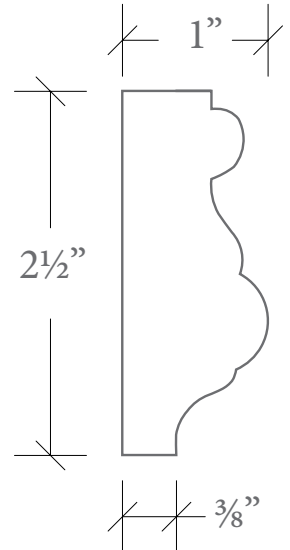

CTM | CH | 13

3/8" x 2 1/2" x 1"

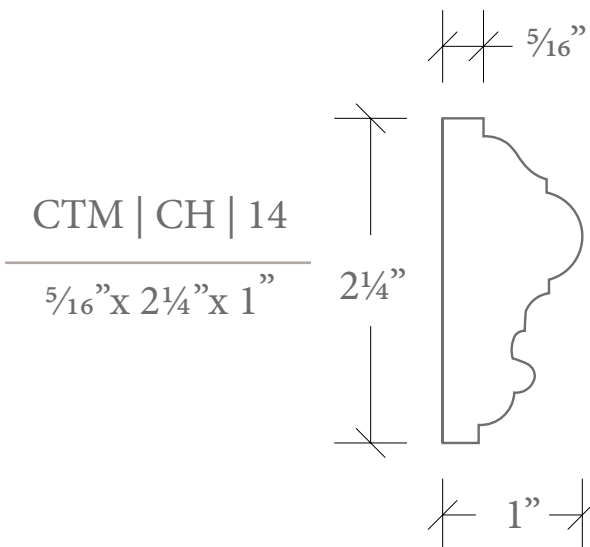

CTM | CH | 14

5/16" x 2 1/4" x 1"

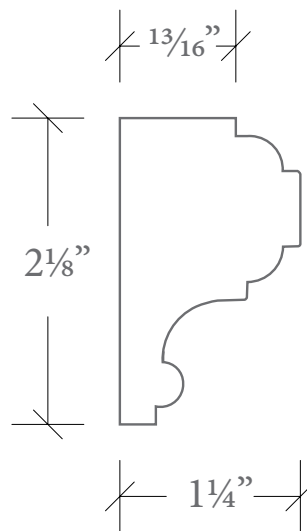

CTM | CH | 15

13/16" x 2 1/8" x 1 1/4"

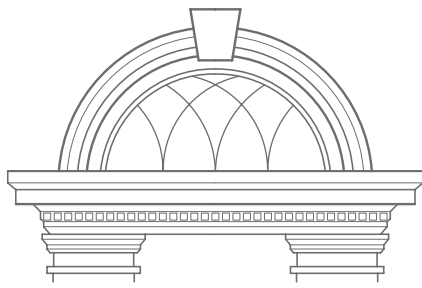

CT MOLDINGS

CTM | CH | 16 ●

$2\frac{1}{16}''$ x $\frac{7}{8}''$

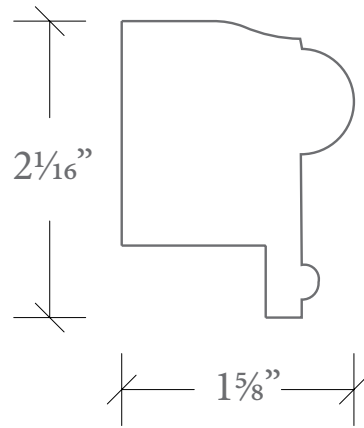
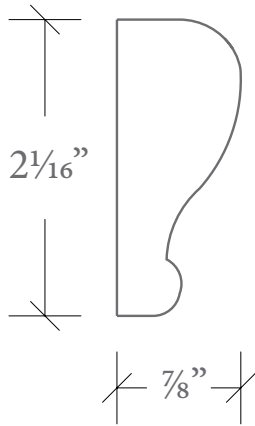

CTM | CH | 17

$2\frac{1}{16}''$ x $1\frac{5}{8}''$

CTM | CH | 18

$\frac{3}{8}''$ x $2''$ x $1\frac{3}{16}''$

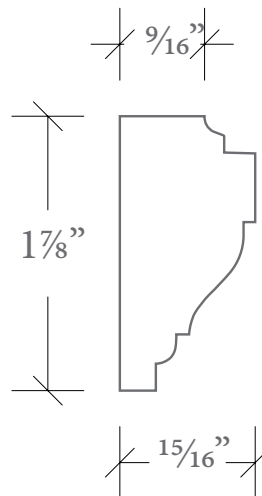
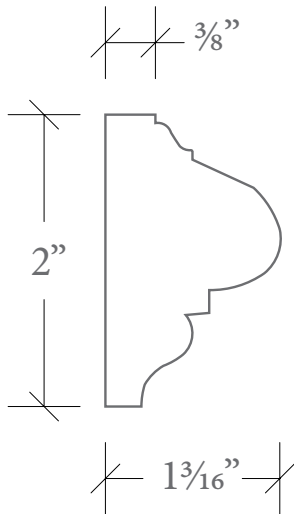

CTM | CH | 19 ●

$\frac{9}{16}''$ x $1\frac{7}{8}''$ x $1\frac{5}{16}''$

● Molding can be curved

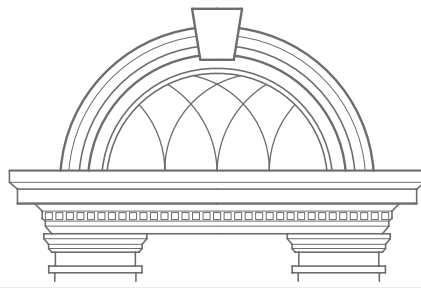

CT MOLDINGS

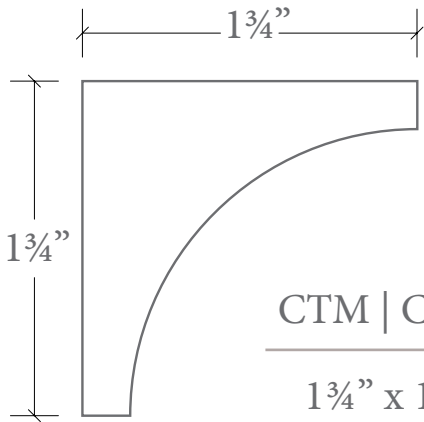

CTM | CV | 1

1 3/4" x 1 3/4"

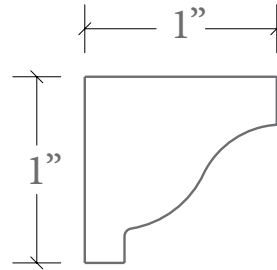

CTM | CV | 2

1" x 1"

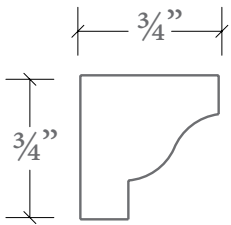

CTM | CV | 3

3/4" x 3/4"

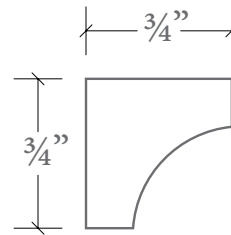

CTM | CV | 4

3/4" x 3/4"

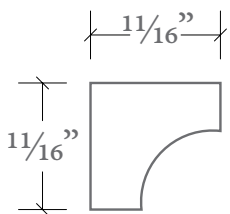

CTM | CV | 5

11/16" x 11/16"

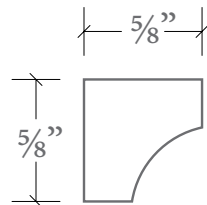

CTM | CV | 6

5/8" x 5/8"

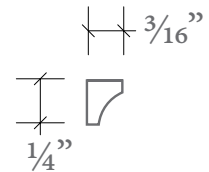

CTM | CV | 7 ●

3/16" x 1/4"

● Molding can be curved



CT MOLDINGS

CROWN



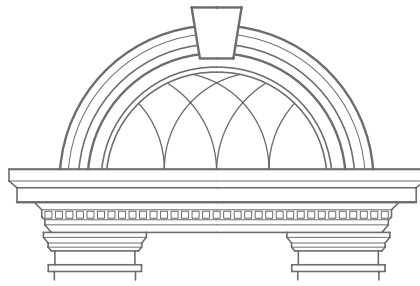

CT MOLDINGS

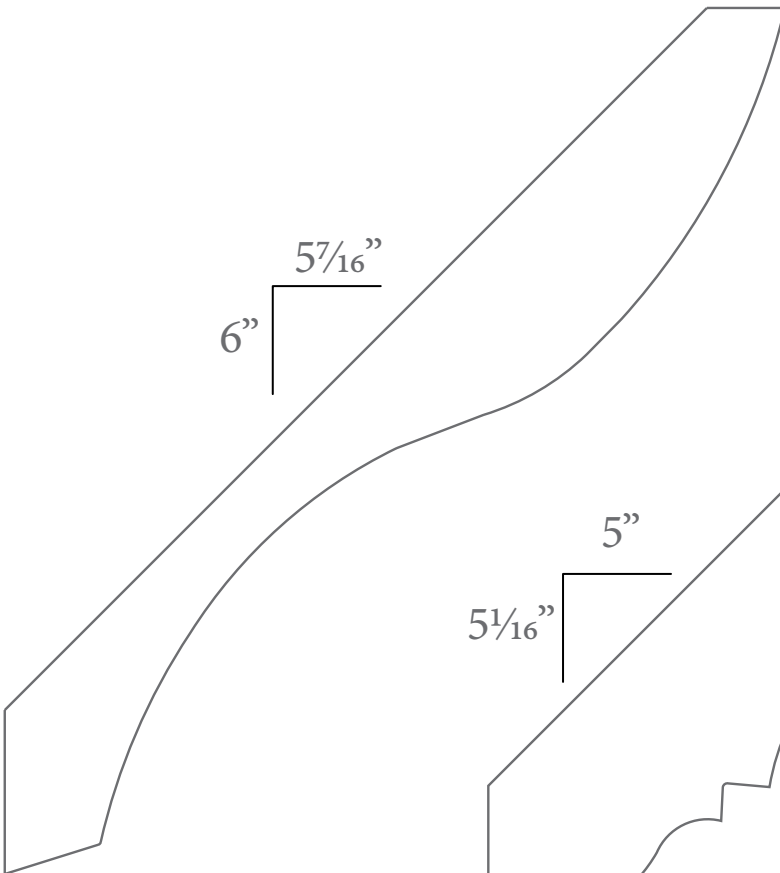

CTM | CR | 01

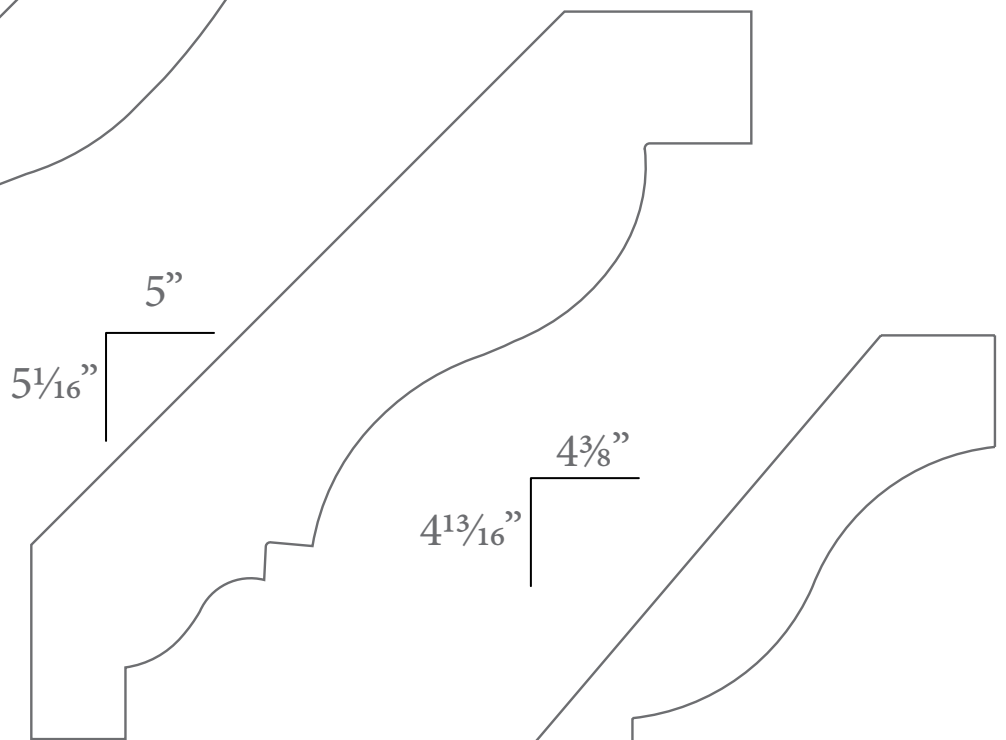

CTM | CR | 02 ●

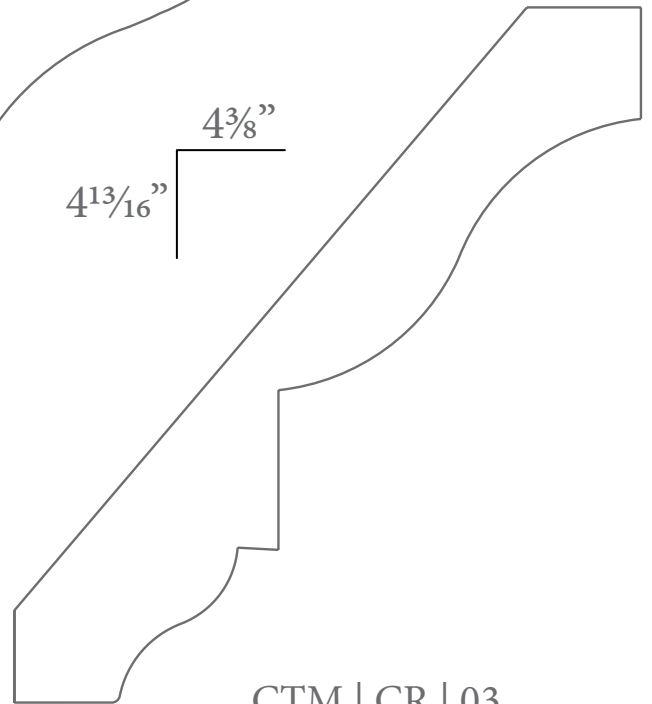

CTM | CR | 03

● Molding can be curved

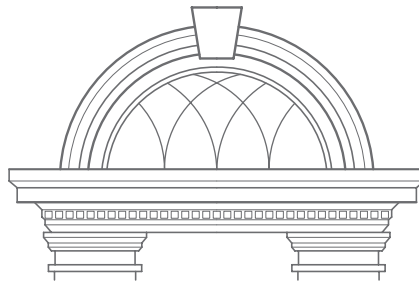

CT MOLDINGS

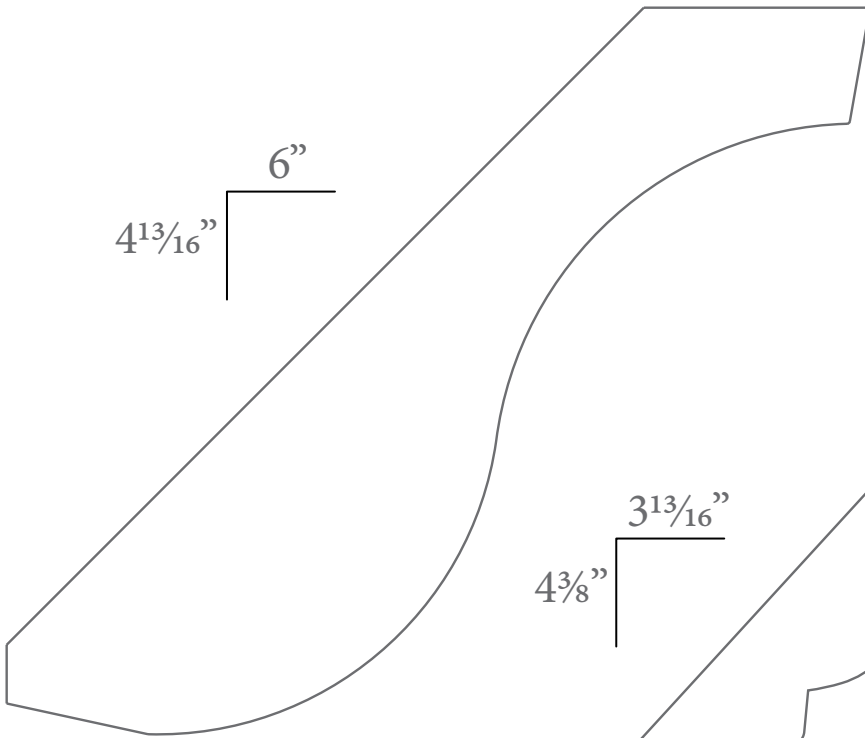

CTM | CR | 04

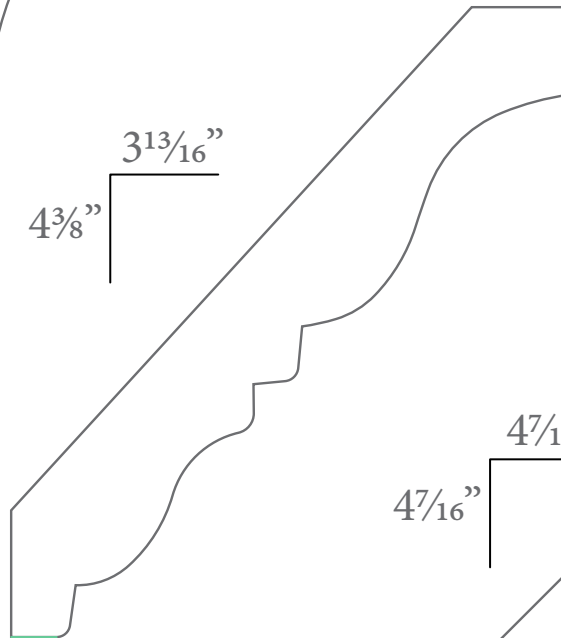

CTM | CR | 05 ●

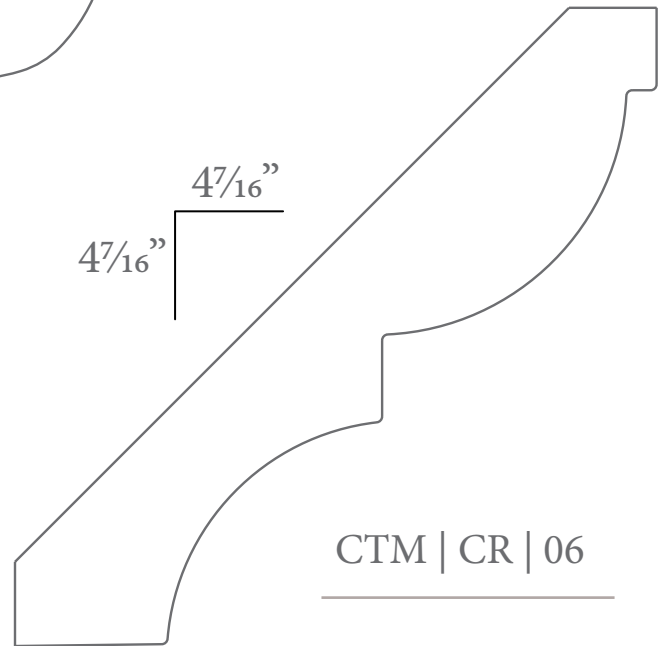

CTM | CR | 06

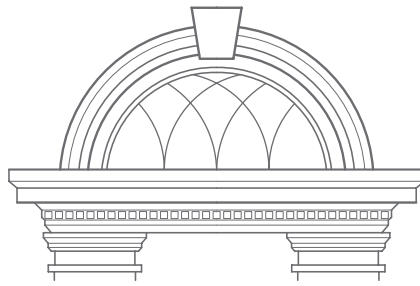

CT MOLDINGS

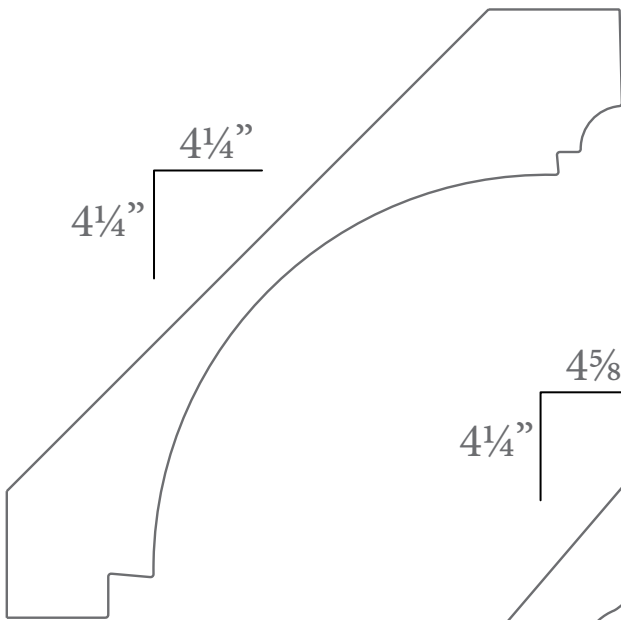

CTM | CR | 07 ●

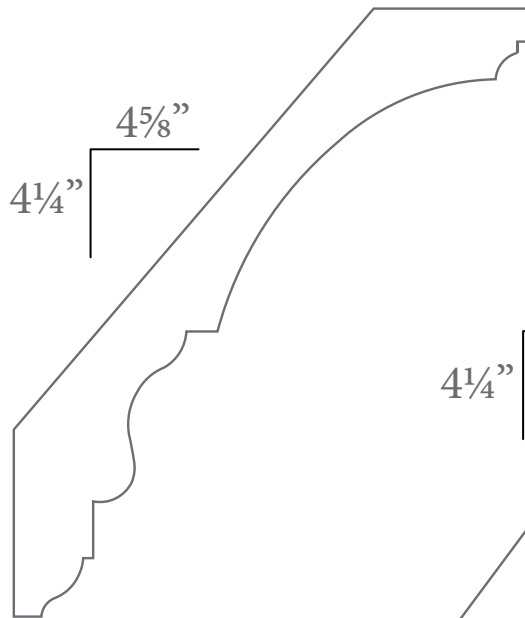

CTM | CR | 08

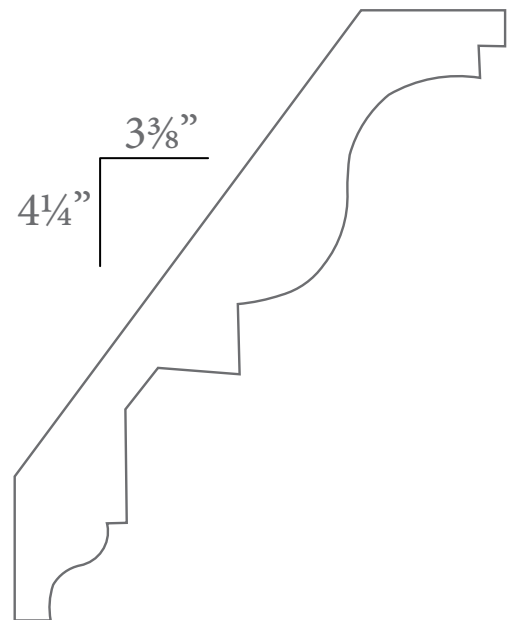

CTM | CR | 09

● Molding can be curved

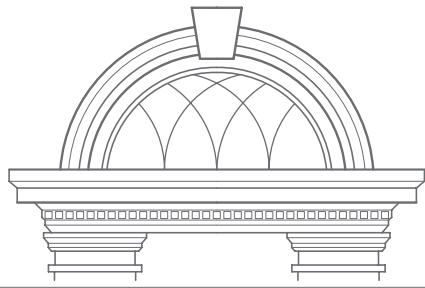

CT MOLDINGS

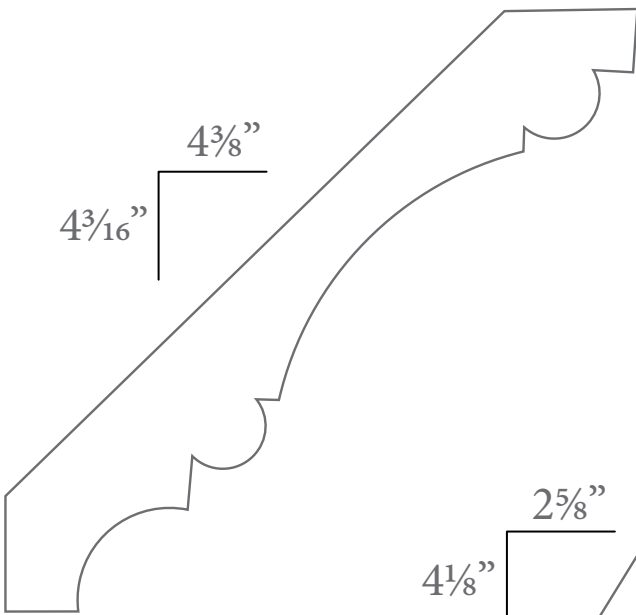

CTM | CR | 10

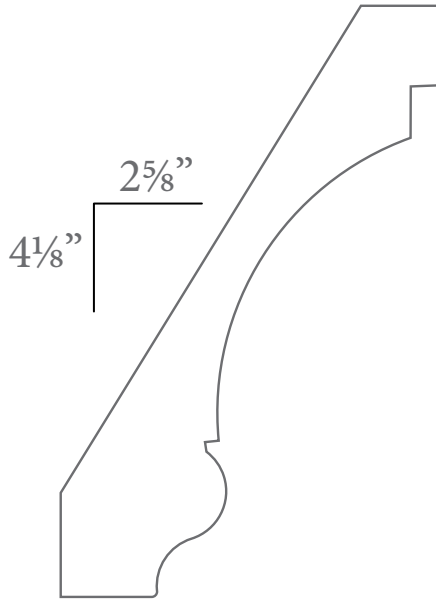

CTM | CR | 11 ●

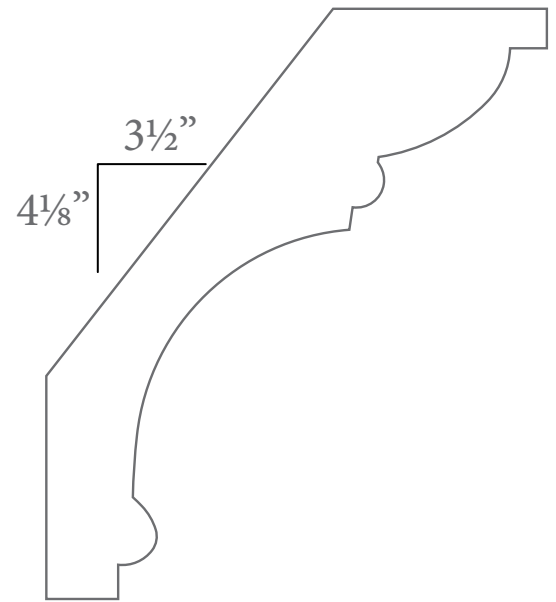

CTM | CR | 12 ●

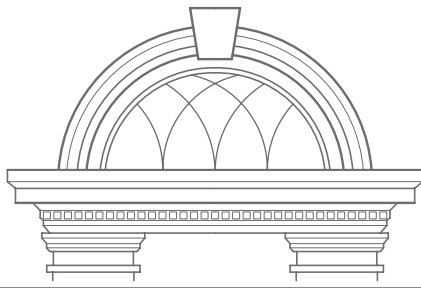

CT MOLDINGS

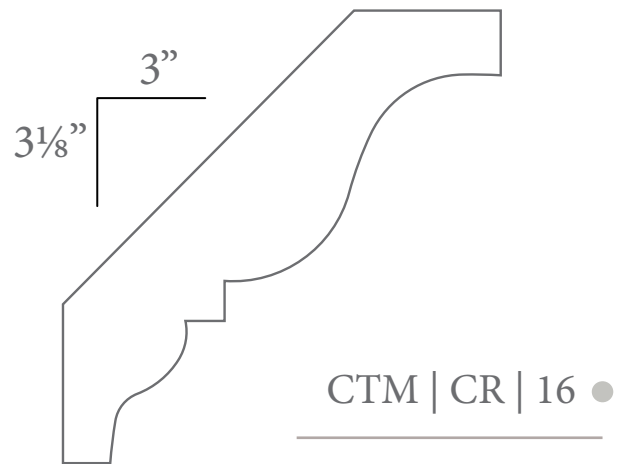
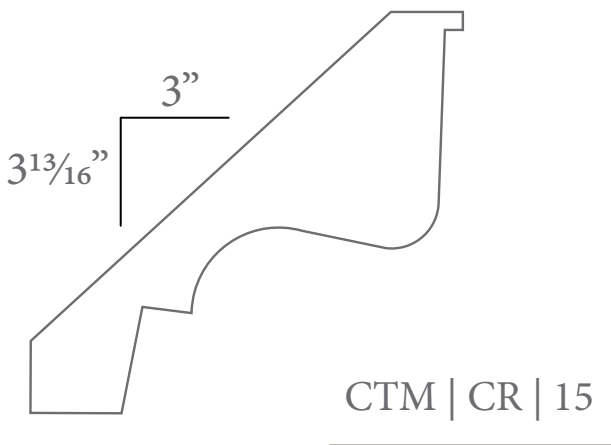
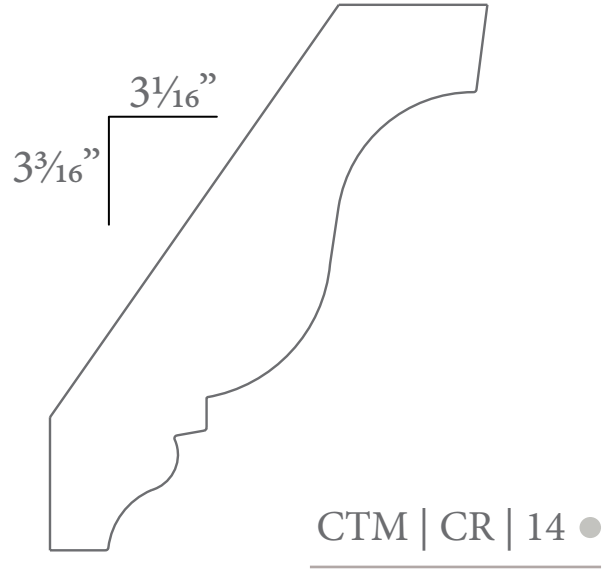
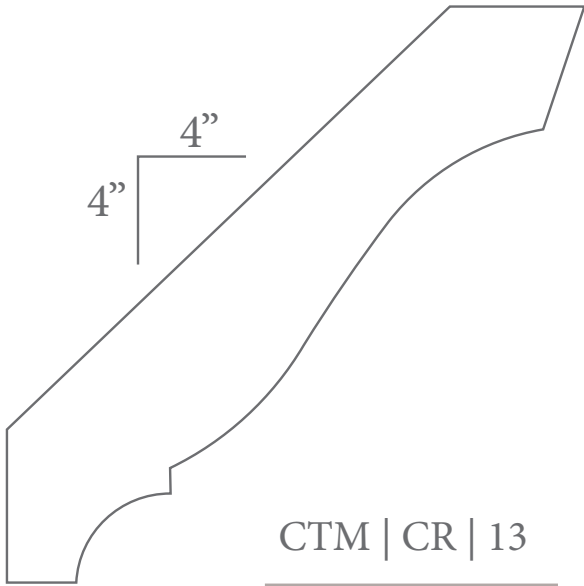

● Molding can be curved

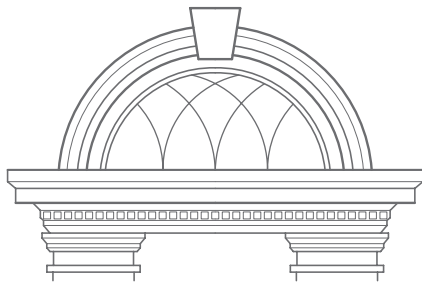

CT MOLDINGS

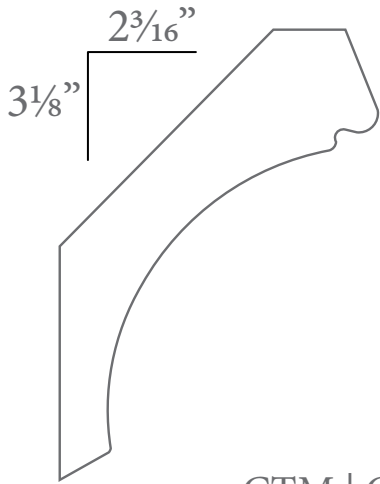

CTM | CR | 17 ●

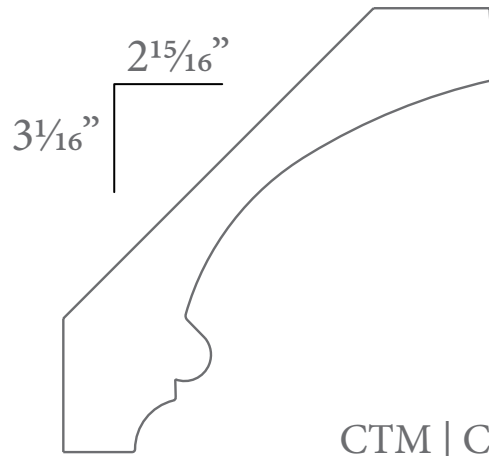

CTM | CR | 18

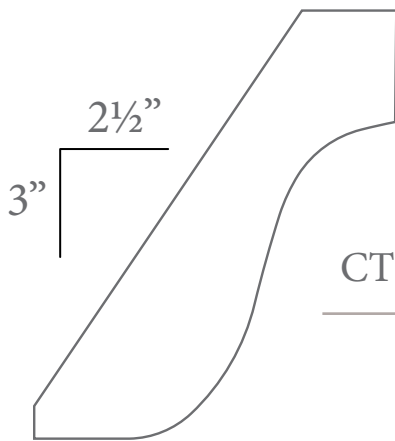

CTM | CR | 19 ●

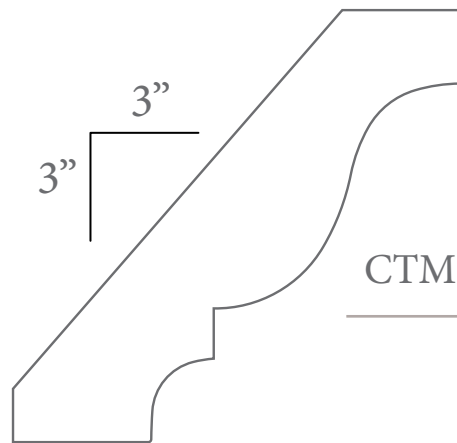

CTM | CR | 20 ●

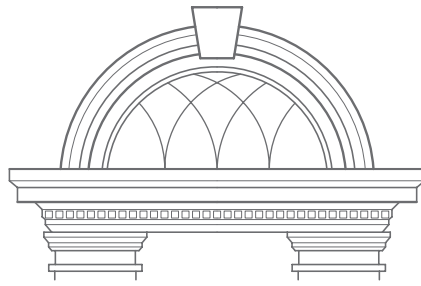

CT MOLDINGS

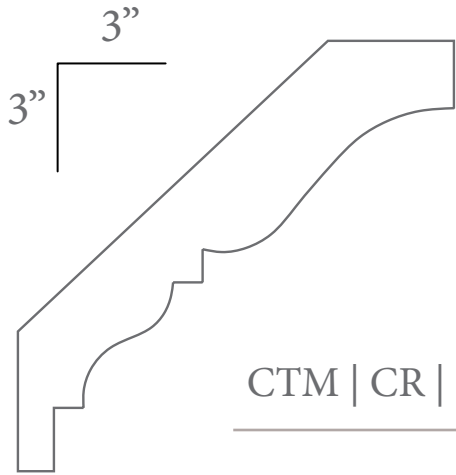

CTM | CR | 21 ●

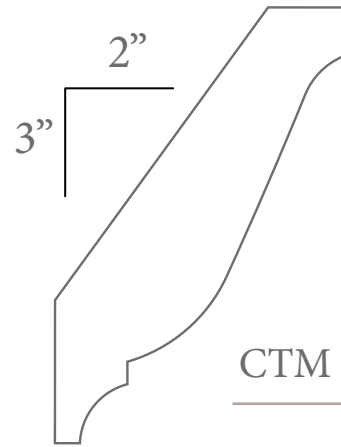

CTM | CR | 22

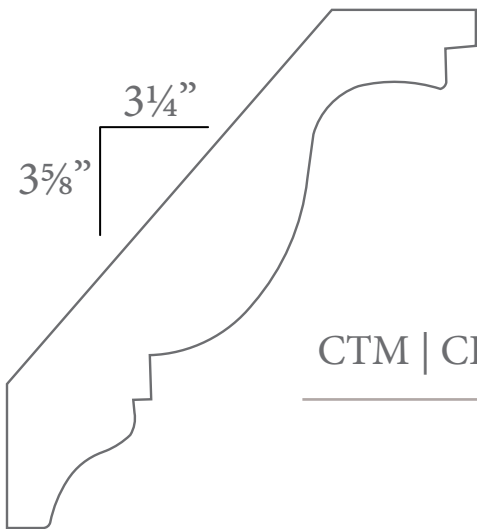

CTM | CR | 23

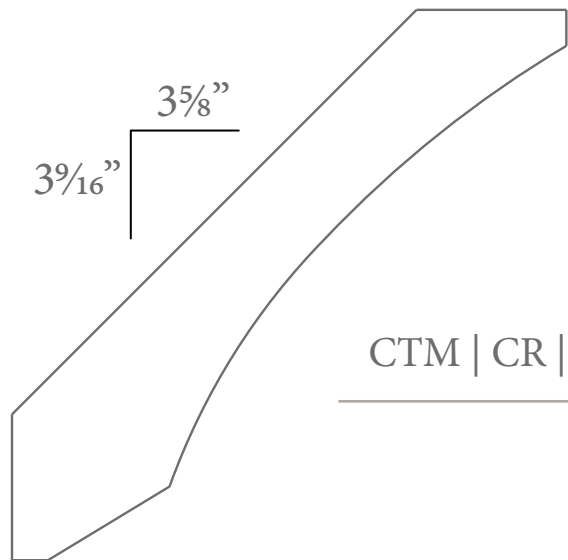

CTM | CR | 24

● Molding can be curved

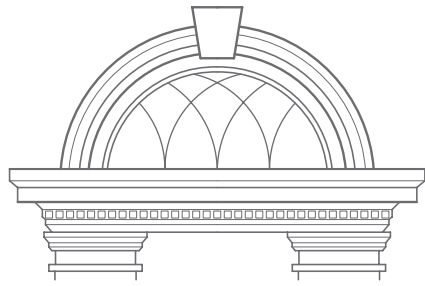

CT MOLDINGS

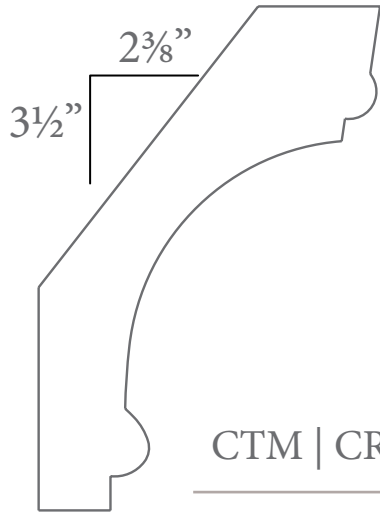

CTM | CR | 25

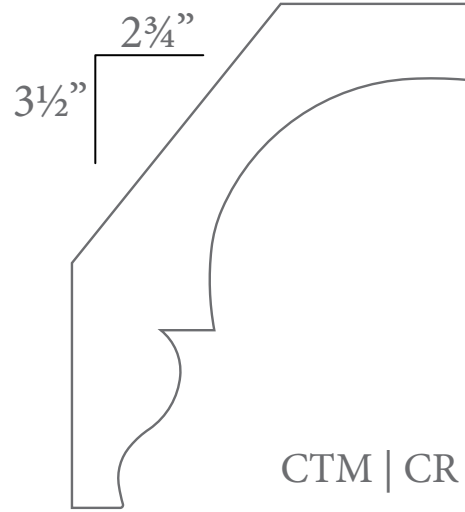

CTM | CR | 26 ●

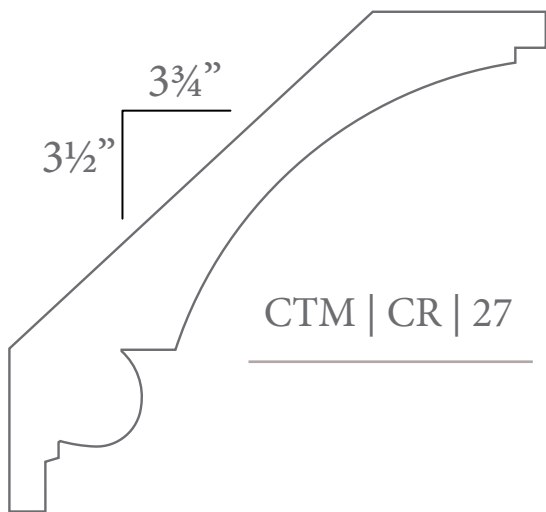

CTM | CR | 27

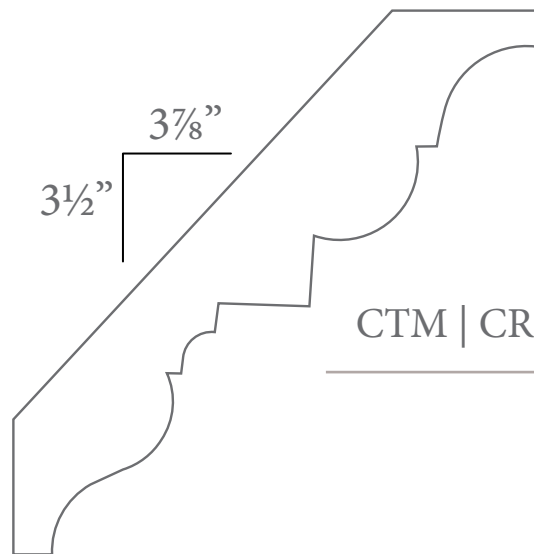

CTM | CR | 28

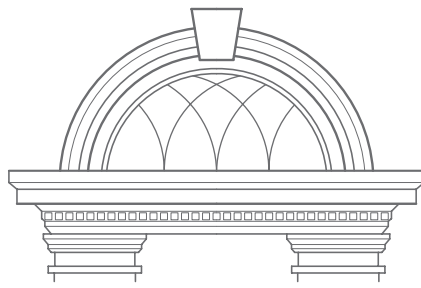

CT MOLDINGS

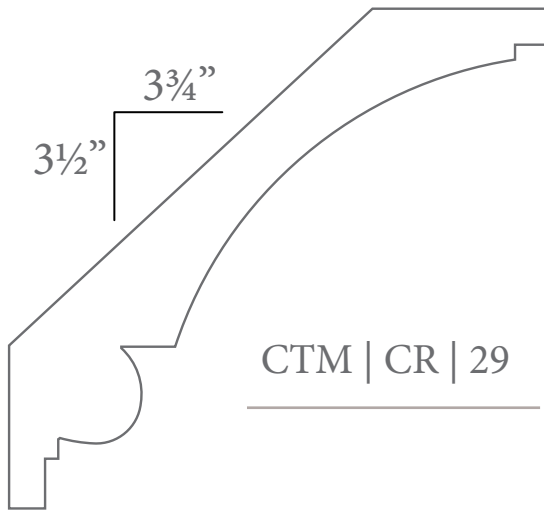

CTM | CR | 29

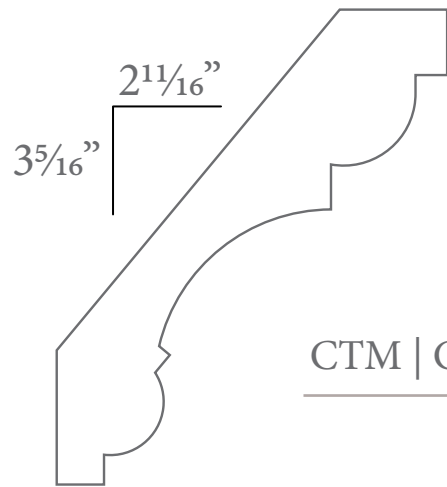

CTM | CR | 30 ●

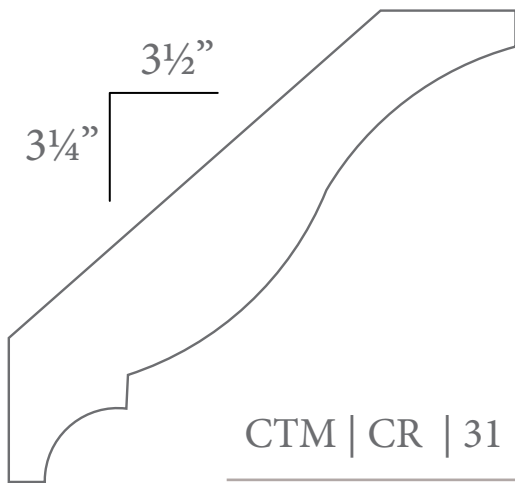

CTM | CR | 31

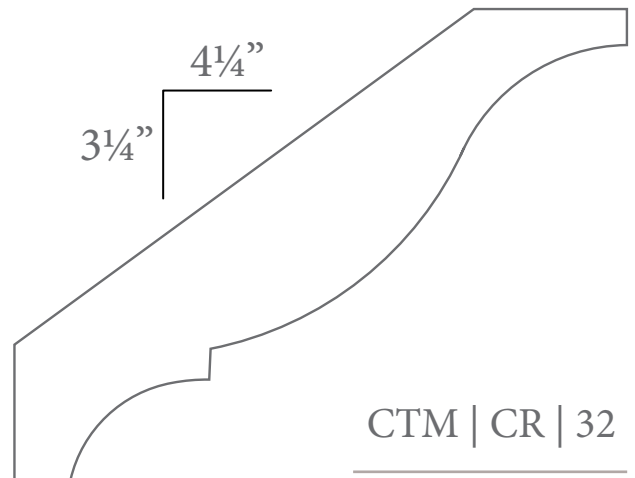

CTM | CR | 32

● Molding can be curved

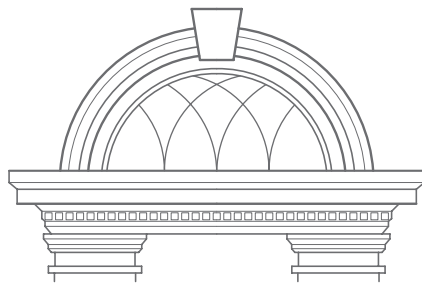

CT MOLDINGS

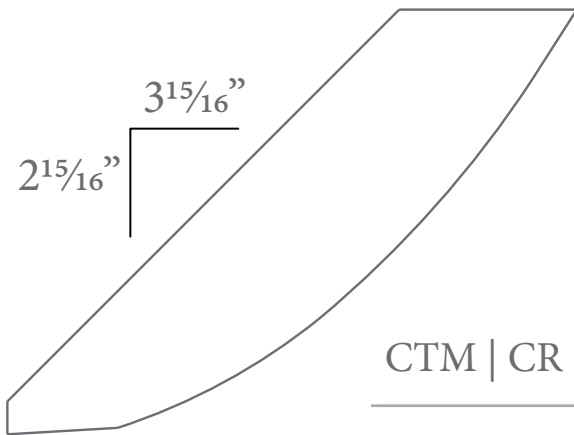

CTM | CR | 33

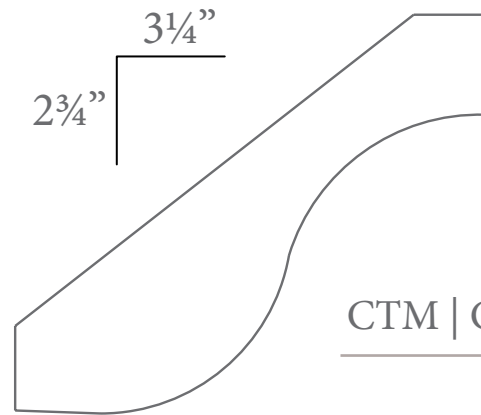

CTM | CR | 34 ●

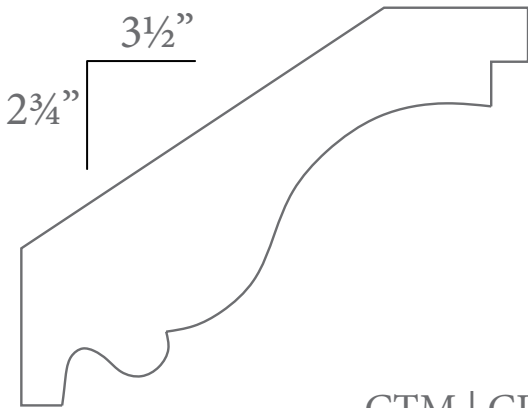

CTM | CR | 35 ●

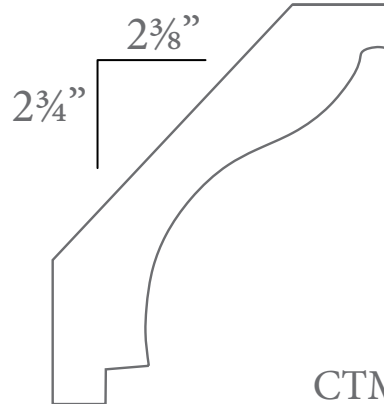

CTM | CR | 36 ●

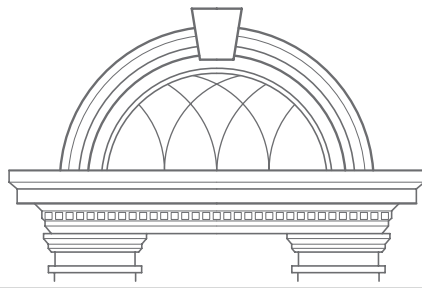

CT MOLDINGS

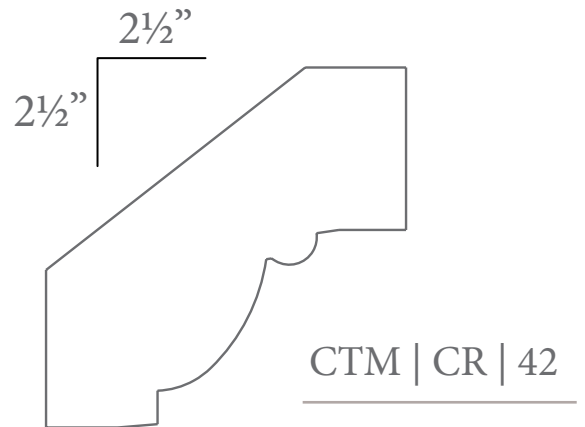
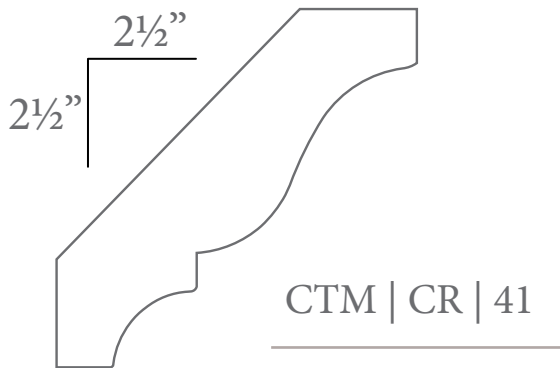
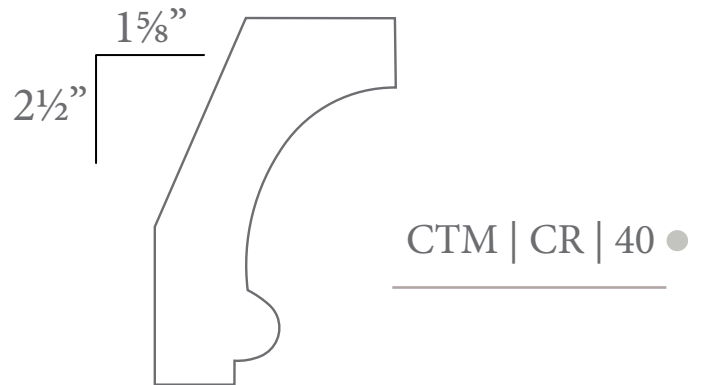
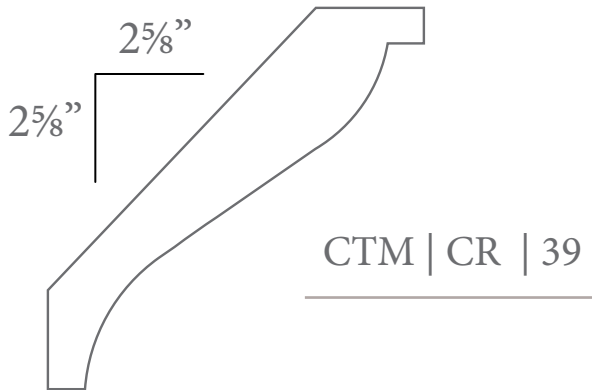
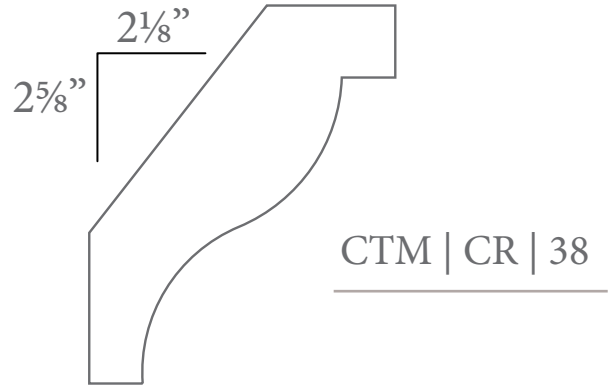
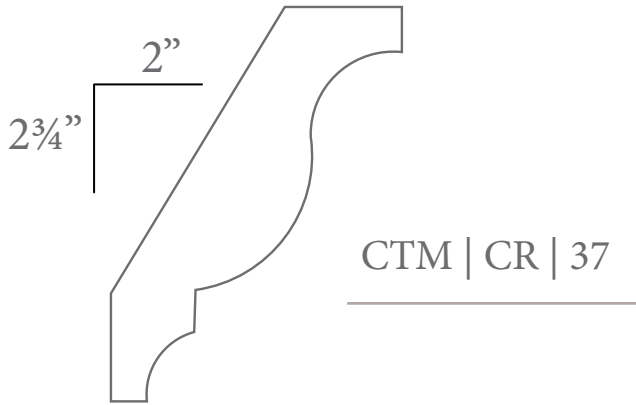

● Molding can be curved

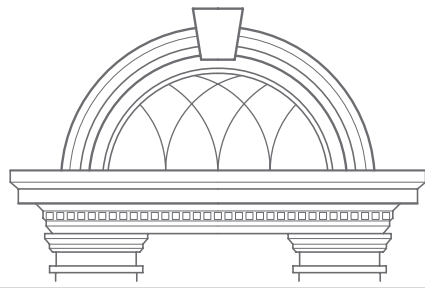

CT MOLDINGS

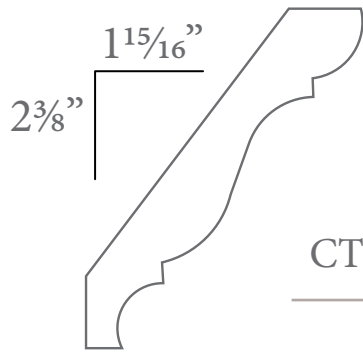

CTM | CR | 43

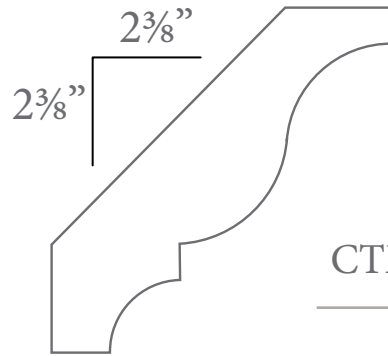

CTM | CR | 44

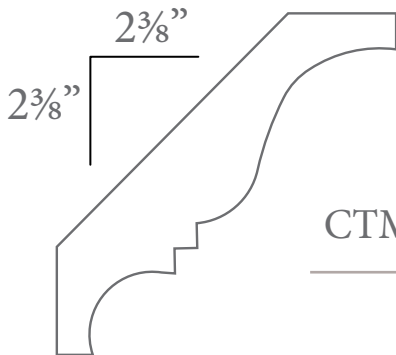

CTM | CR | 45

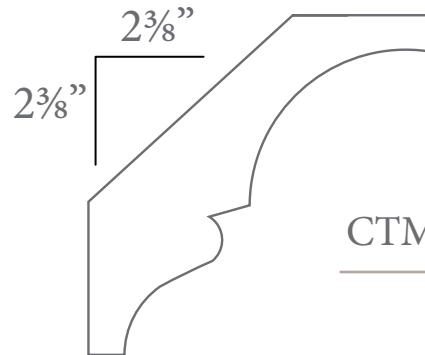

CTM | CR | 46

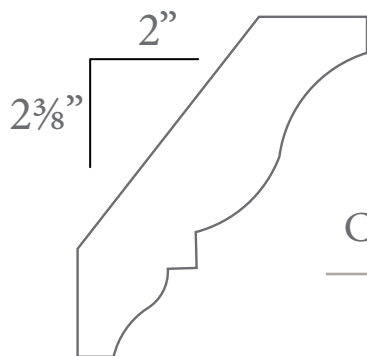

CTM | CR | 47

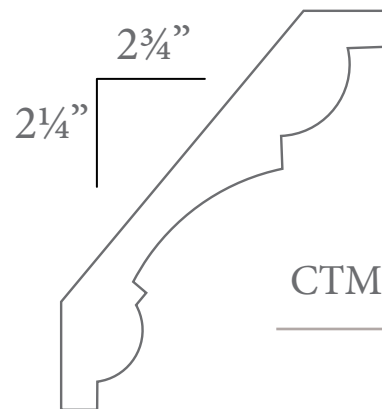

CTM | CR | 48

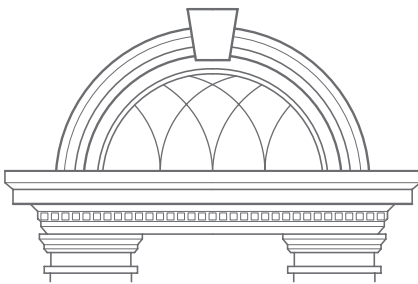

CT MOLDINGS

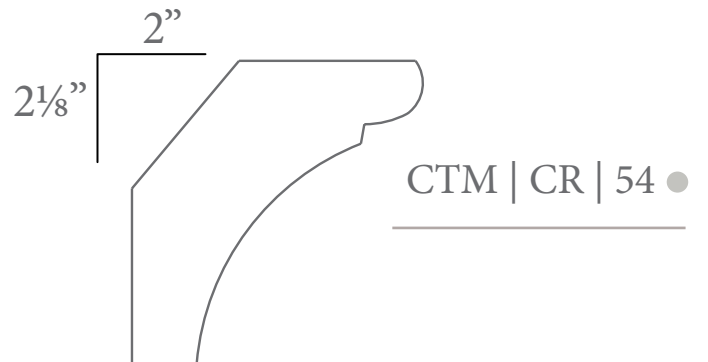
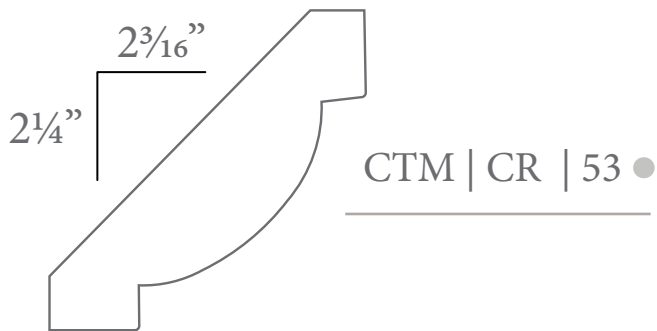
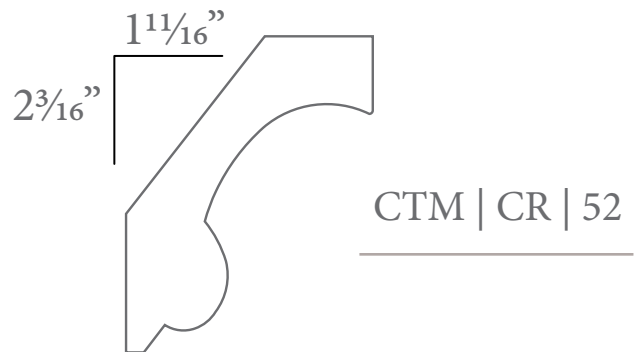
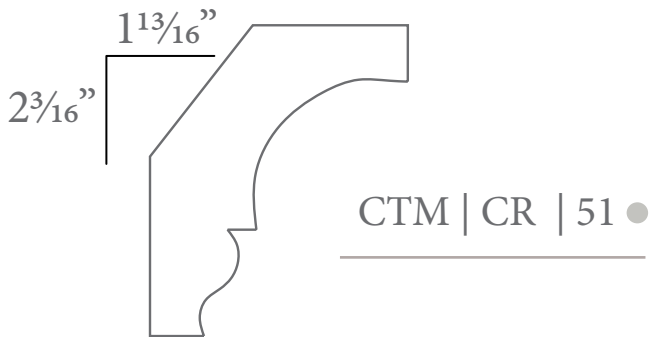
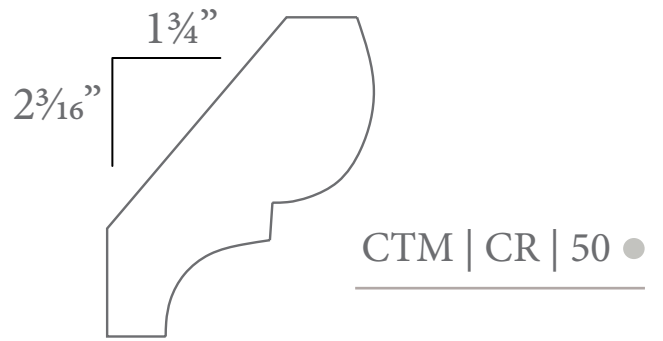
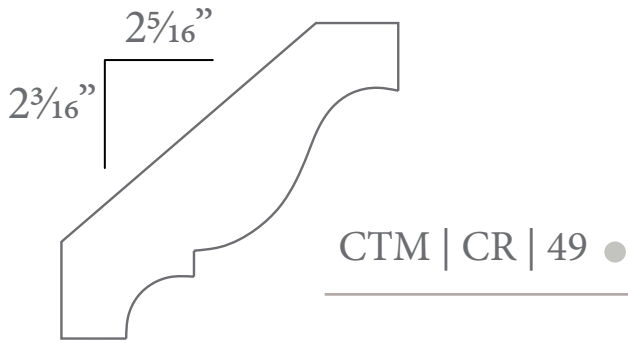

● Molding can be curved

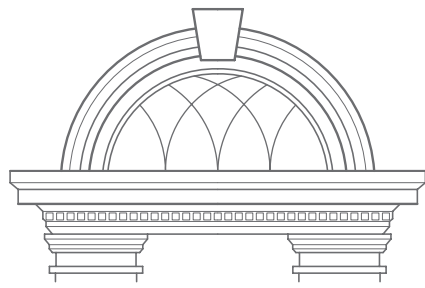

CT MOLDINGS

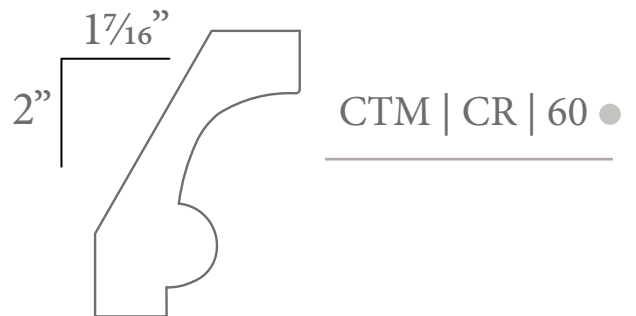
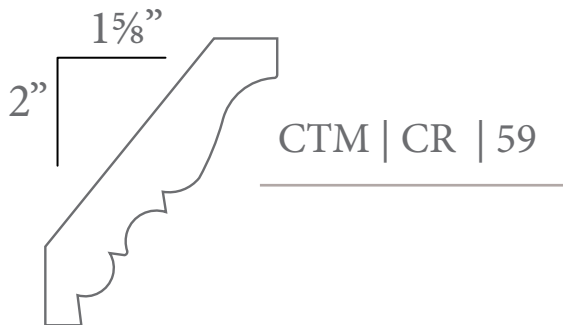
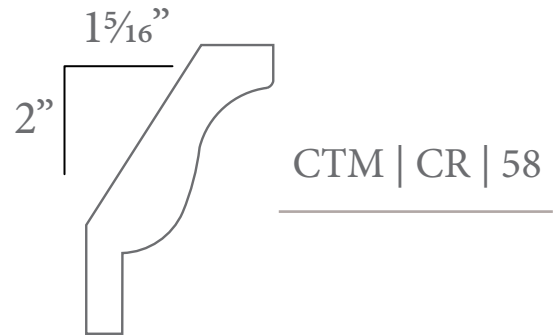
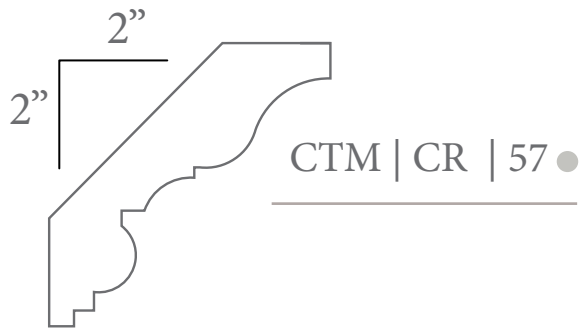
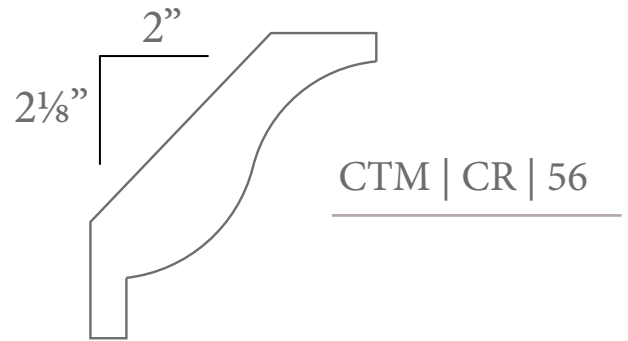
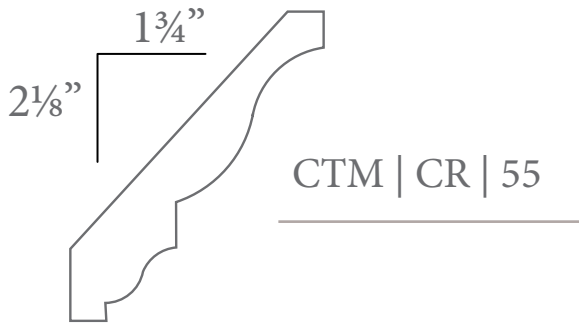

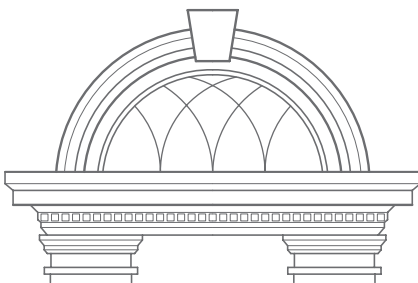

CT MOLDINGS

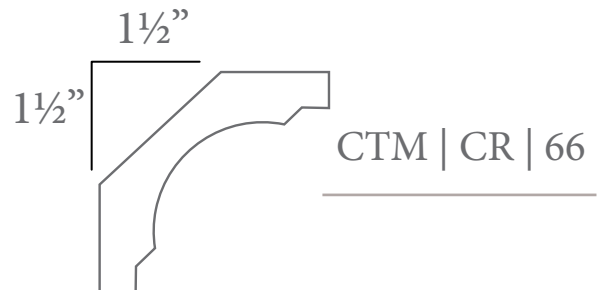
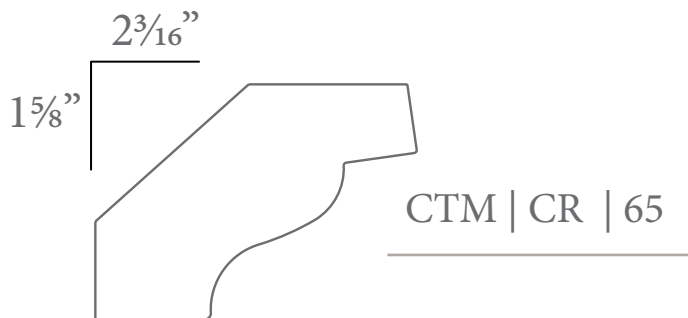
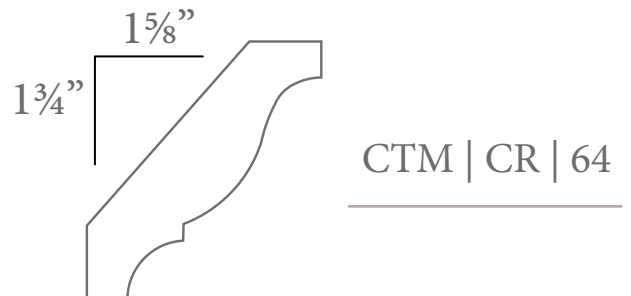
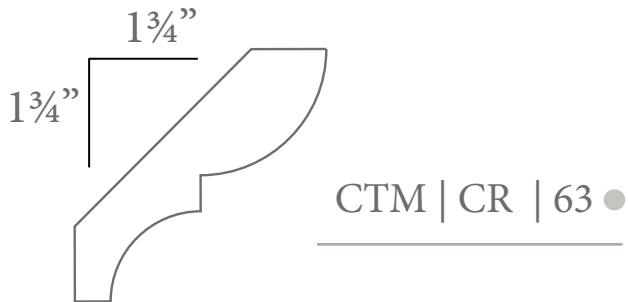
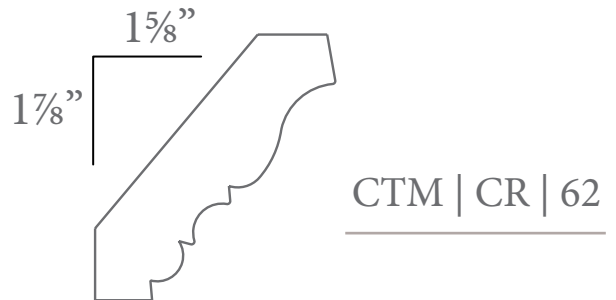
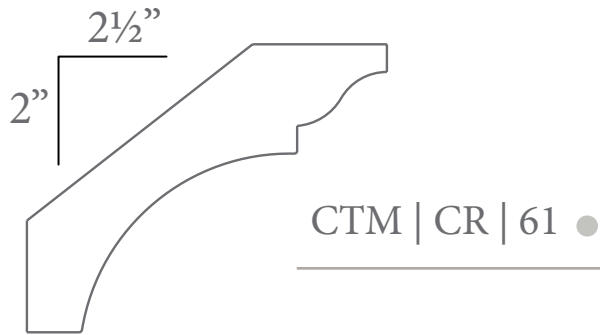

● Molding can be curved

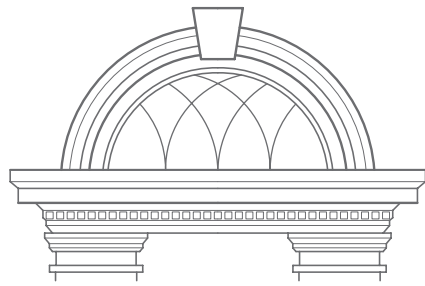

CT MOLDINGS

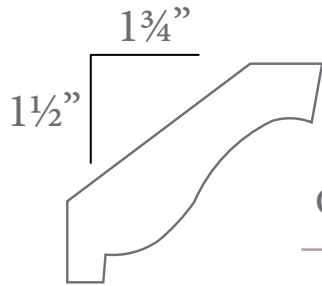

CTM | CR | 67

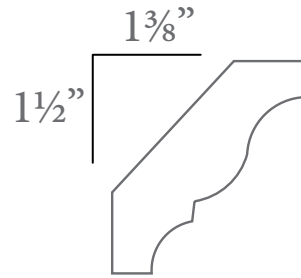

CTM | CR | 68

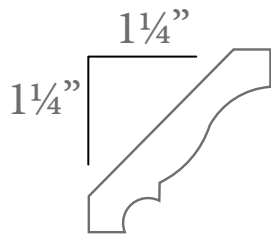

CTM | CR | 69



SOLID CROWN



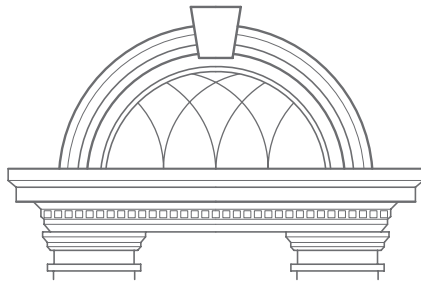

CT MOLDINGS

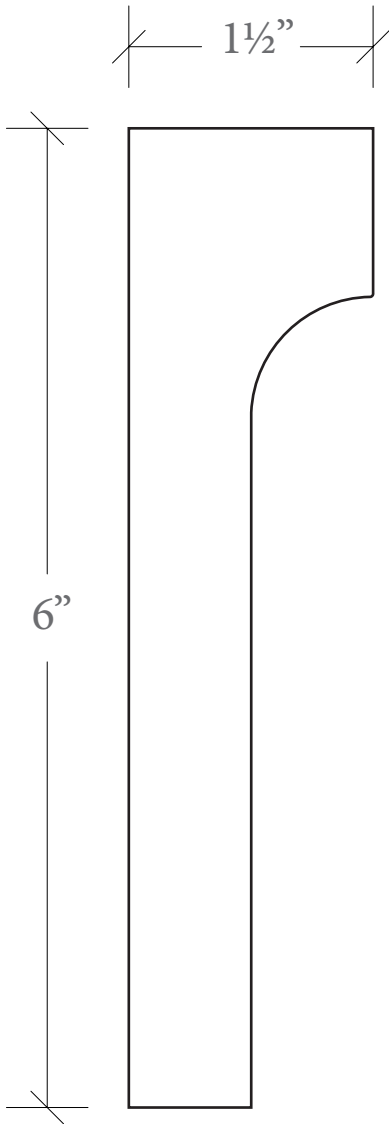

CTM | SC | 01

6" x 1 1/2"

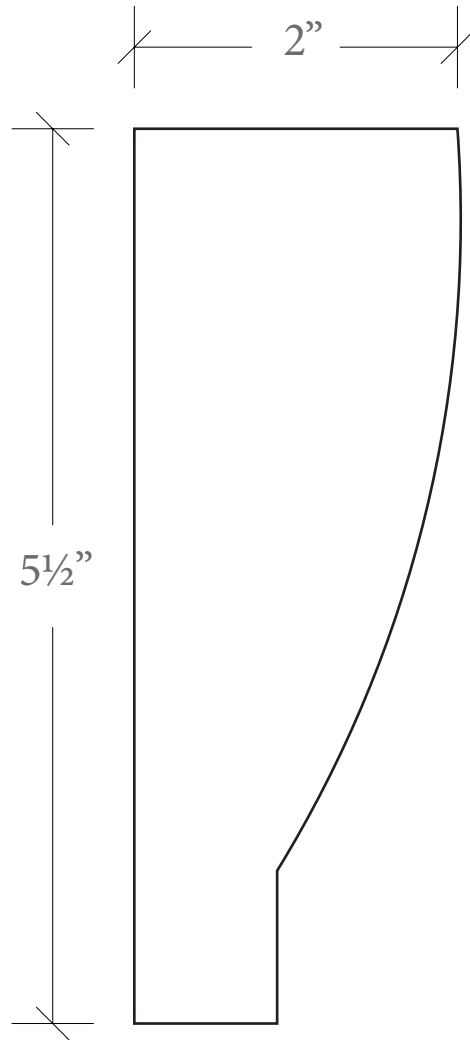

CTM | SC | 02 ●

5 1/2" x 2"

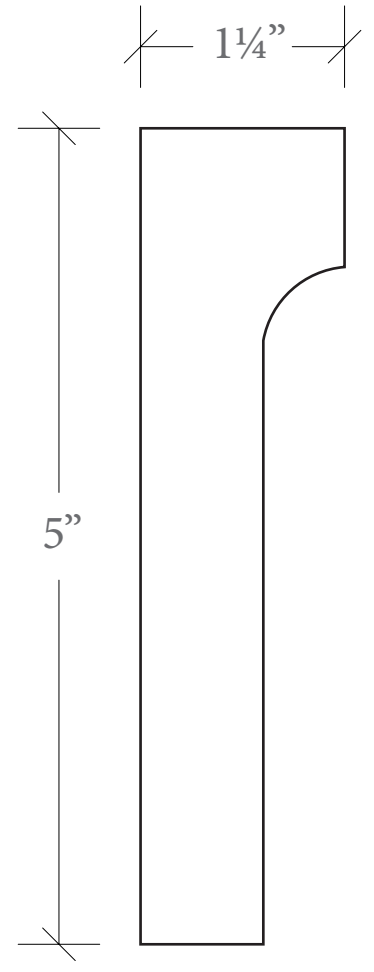

CTM | SC | 03

5" x 1 1/4"

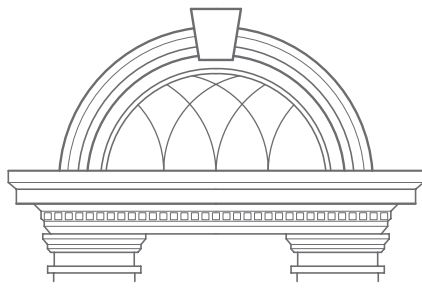

CT MOLDINGS

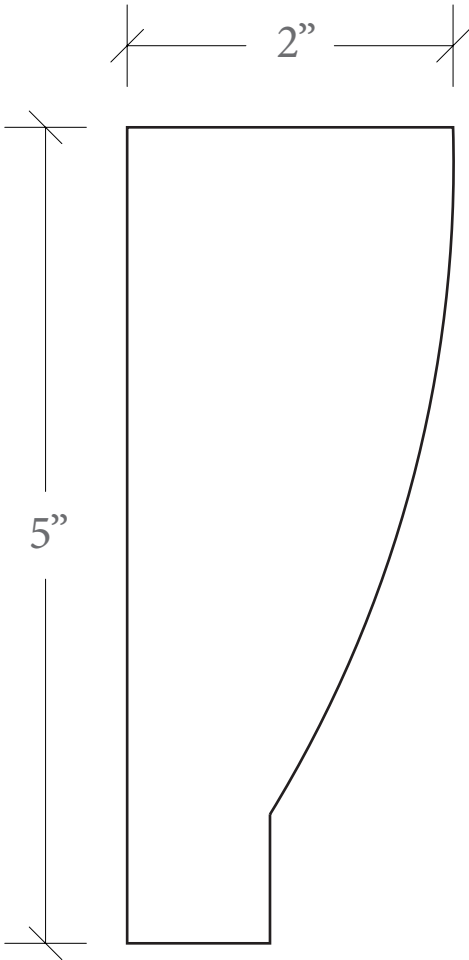

CTM | SC | 04 ●

5" x 2"

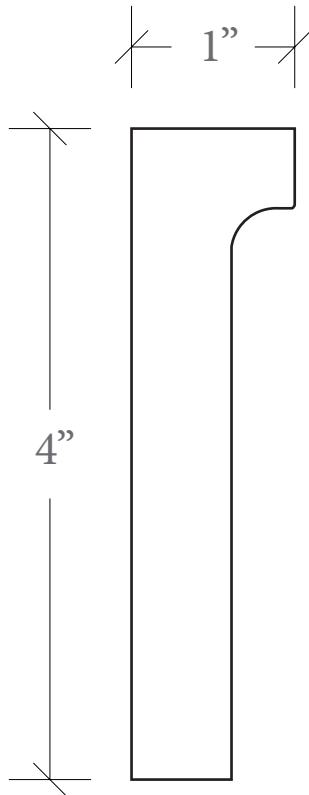

CTM | SC | 05

4" x 1"

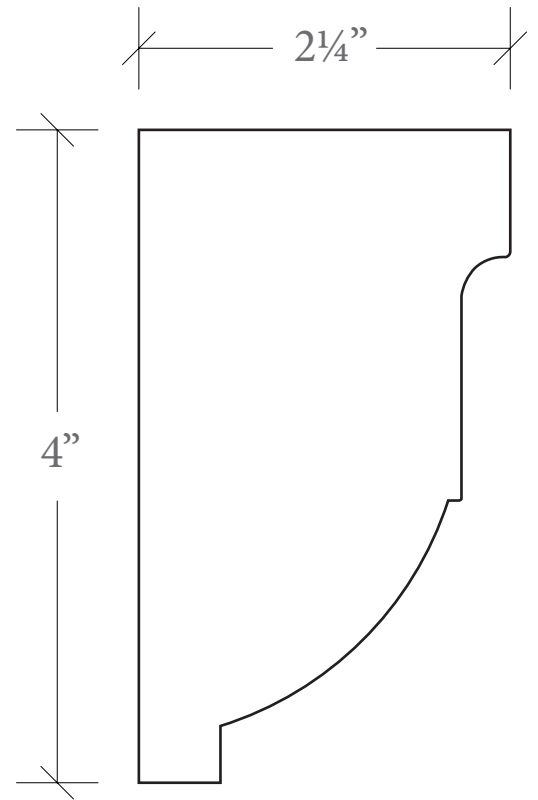

CTM | SC | 06

4" x 2 1/4"

● Molding can be curved

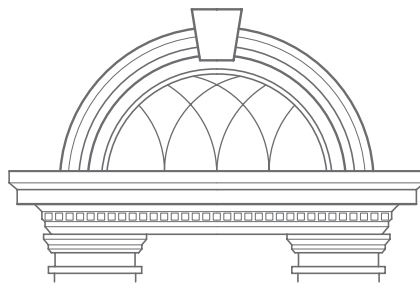

CT MOLDINGS

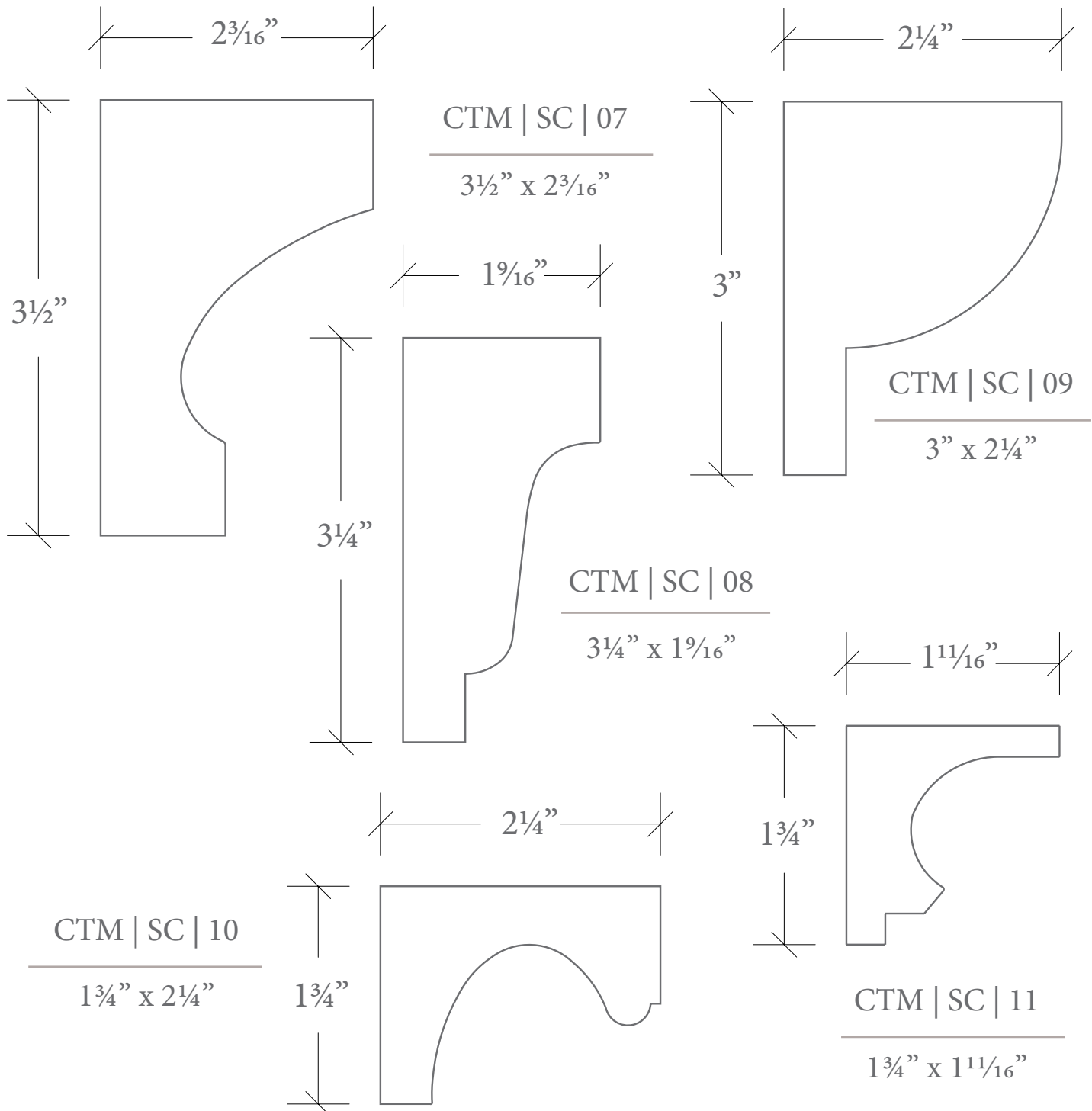

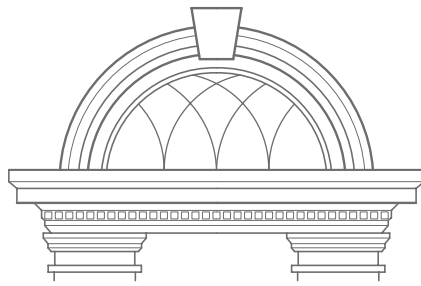

CT MOLDINGS

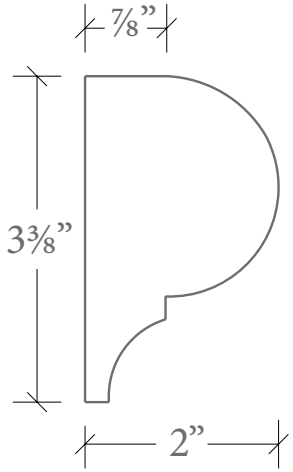

CTM | ED | 1

7/8" x 3 3/8" x 2"

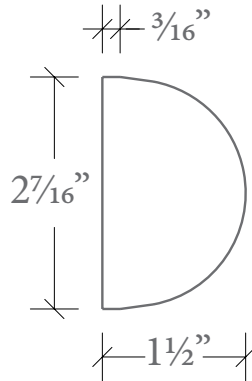

CTM | ED | 2

3/16" x 2 7/16" x 1 1/2"

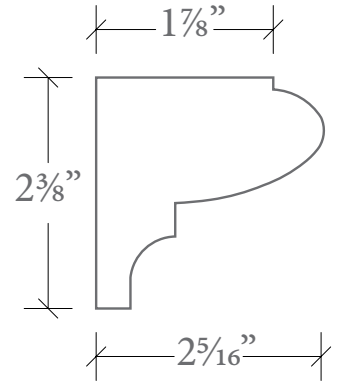

CTM | ED | 3

1 7/8" x 2 3/8" x 2 5/16"

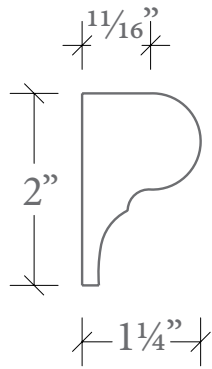

CTM | ED | 4 ●

1 1/16" x 2" x 1 1/4"

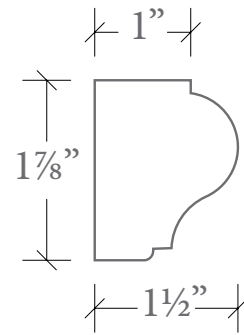

CTM | ED | 5

1" x 1 7/8" x 1 1/2"

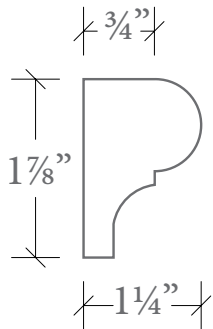

CTM | ED | 6

3/4" x 1 7/8" x 1 1/4"

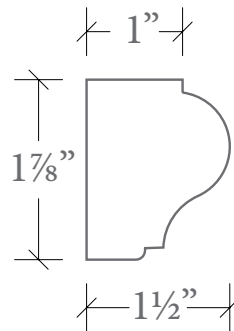

CTM | ED | 7 ●

1" x 1 7/8" x 1 1/2"

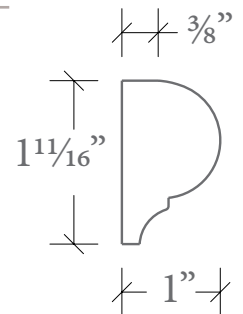

CTM | ED | 8

3/8" x 1 11/16" x 1"

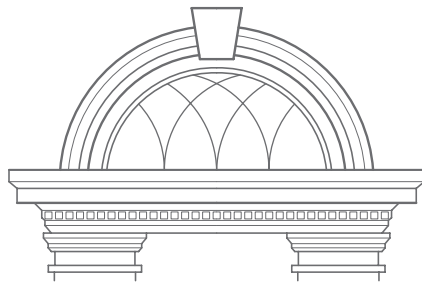

CT MOLDINGS

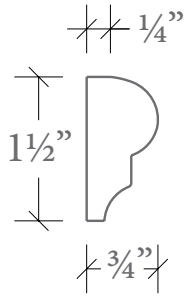

CTM | ED | 9 ●

1/4" x 1 1/2" x 3/4"

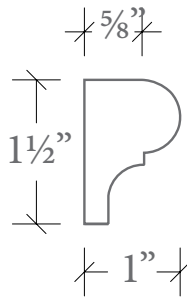

CTM | ED | 10 ●

5/8" x 1 1/2" x 1"

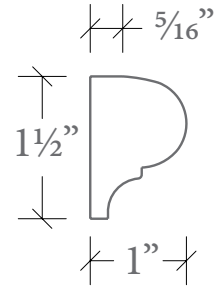

CTM | ED | 11

5/16" x 1 1/2" x 1"

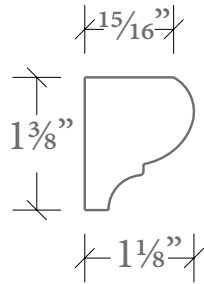

CTM | ED | 12

15/16" x 1 3/8" x 1 1/8"

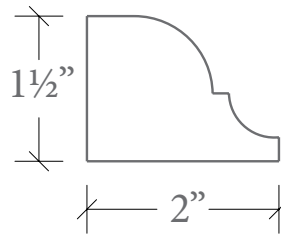

CTM | ED | 13

1 1/2" x 2"

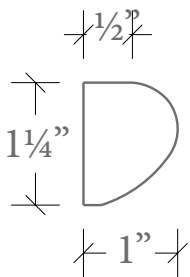

CTM | ED | 14 ●

1/2" x 1 1/4" x 1"

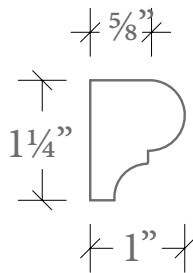

CTM | ED | 15 ●

5/8" x 1 1/4" x 1"

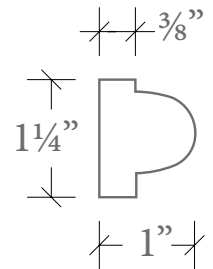

CTM | ED | 16 ●

3/8" x 1 1/4" x 1"

● Molding can be curved

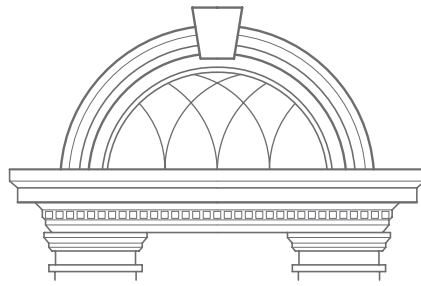

CT MOLDINGS

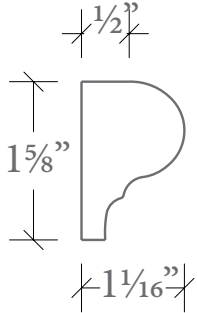

CTM | ED | 17

1/2" X 1 5/8" X 1 1/16"

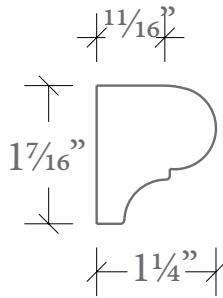

CTM | ED | 18

1 1/16" X 1 7/16" X 1 1/4"

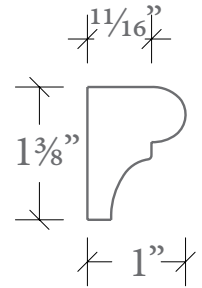

CTM | ED | 19

1 1/16" X 1 3/8" X 1"

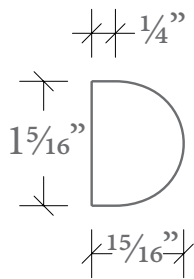

CTM | ED | 20

1/4" X 1 5/16" X 1 5/16"

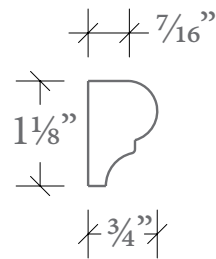

CTM | ED | 21

7/16" X 1 1/8" X 3/4"

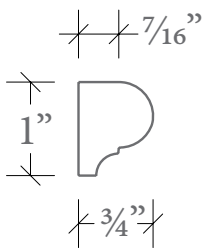

CTM | ED | 22

7/16" X 1" X 3/4"

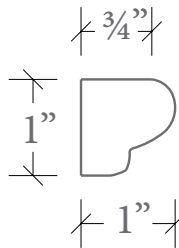

CTM | ED | 23 ●

3/4" X 1" X 1"

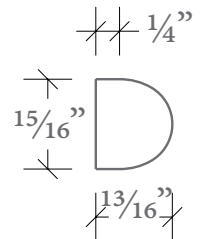

CTM | ED | 24

1/4" X 1 5/16" X 1 3/16"

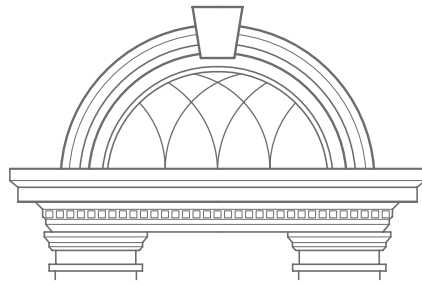

CT MOLDINGS

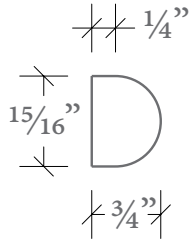

CTM | ED | 25

1/4" X 15/16" X 3/4"

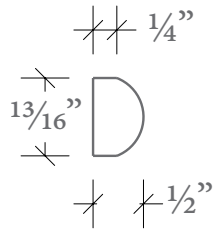

CTM | ED | 26

1/4" X 13/16" X 1/2"

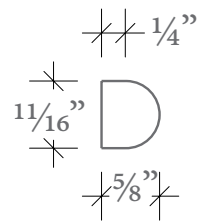

CTM | ED | 27 ●

1/4" X 11/16" X 5/8"

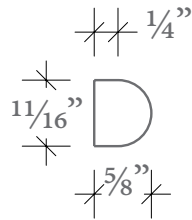

CTM | ED | 28 ●

1/4" X 11/16" X 5/8"

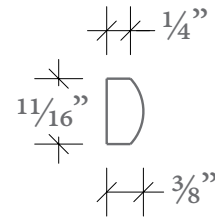

CTM | ED | 29

1/4" X 11/16" X 3/8"

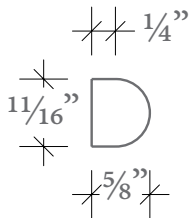

CTM | ED | 30

1/4" X 11/16" X 5/8"

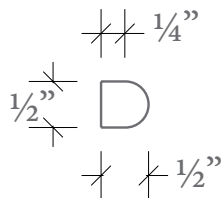

CTM | ED | 31

1/4" X 1/2" X 1/2"

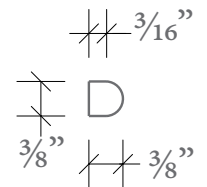

CTM | ED | 32

3/16" X 3/8" X 3/8"

● Molding can be curved

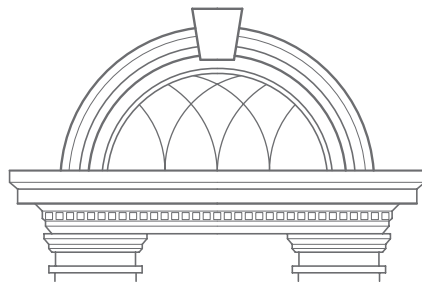

CT MOLDINGS

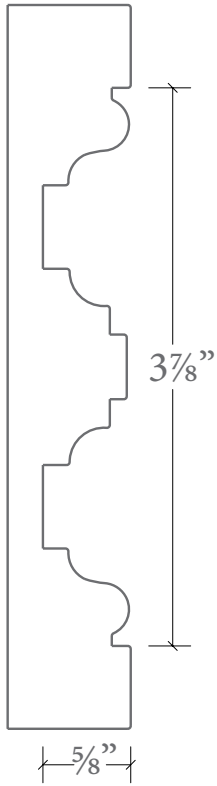

CTM | FL | 1

3 7/8" x 5/8"

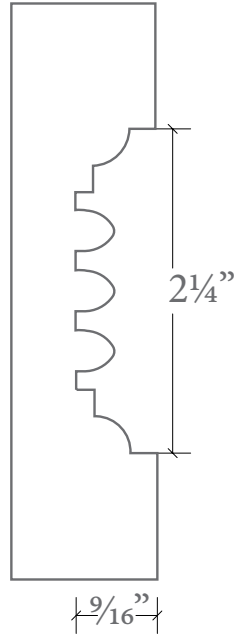

CTM | FL | 2

2 1/4" x 9/16"

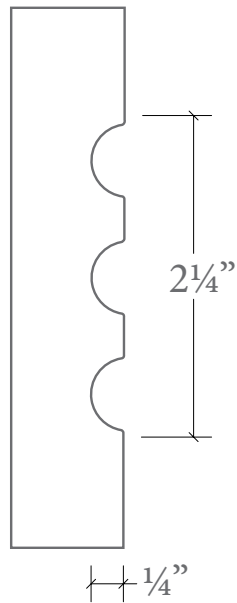

CTM | FL | 3

2 1/4" x 1/4"

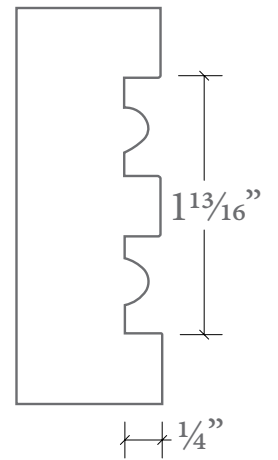

CTM | FL | 4 ●

1 13/16" x 1/4"

● Molding can be curved

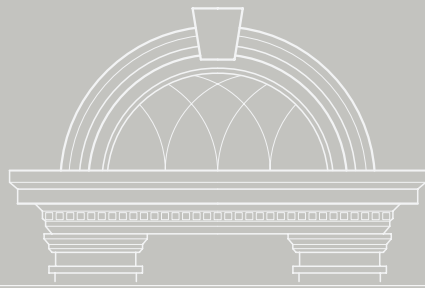

CT MOLDINGS

MULLION

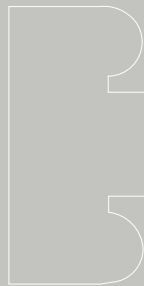
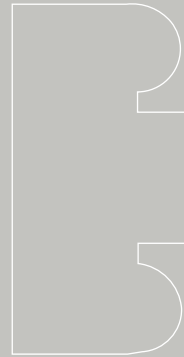

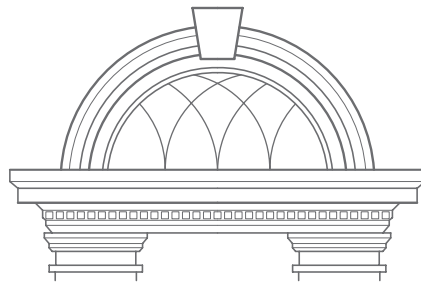

CT MOLDINGS

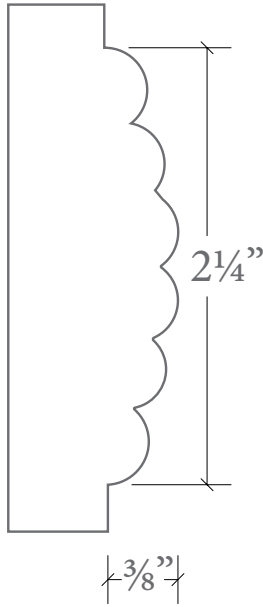

CTM | MU | 01

2 1/4" x 3/8"

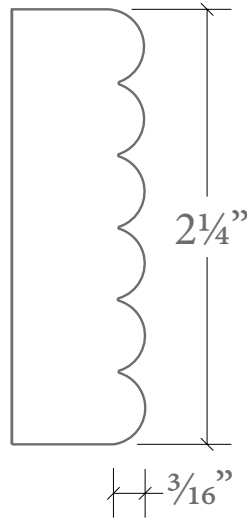

CTM | MU | 02

2 1/4" x 3/16"

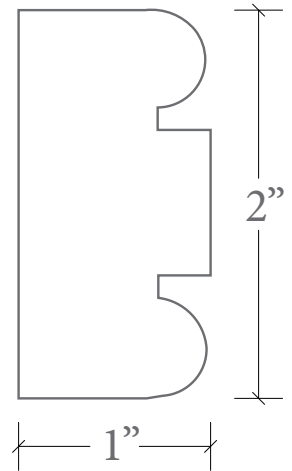

CTM | MU | 03

2" x 1"

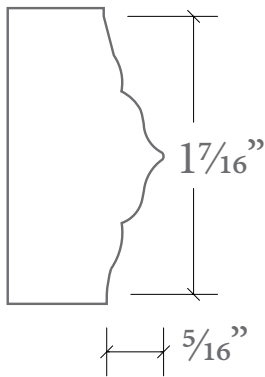

CTM | MU | 04

1 7/16" x 5/16"

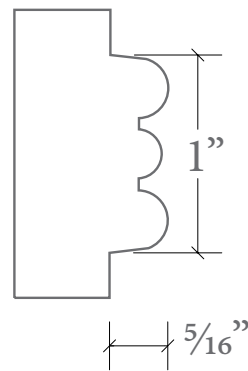

CTM | MU | 05

1" x 5/16"

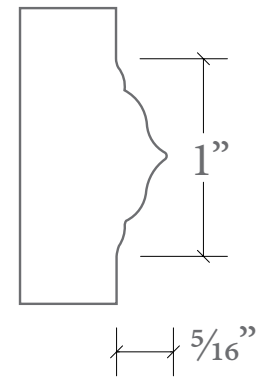

CTM | MU | 06

1" x 5/16"

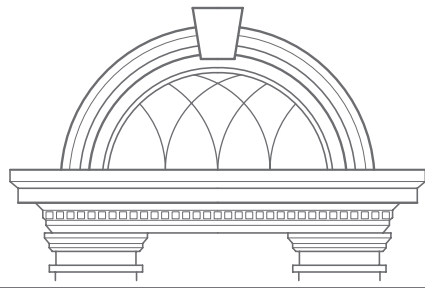

CT MOLDINGS

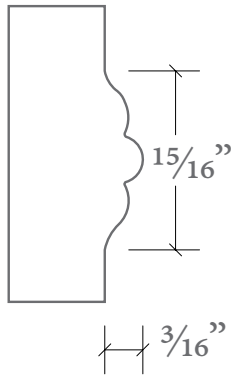

CTM | MU | 07

15/16" X 3/16"

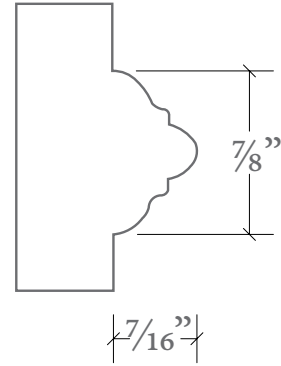

CTM | MU | 08

7/8" X 7/16"

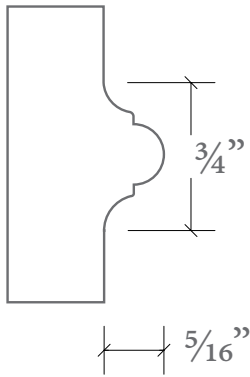

CTM | MU | 09

3/4" X 5/16"

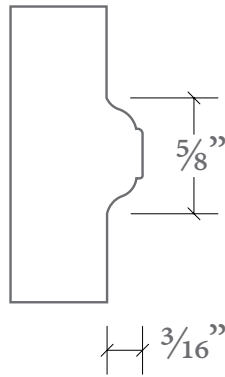

CTM | MU | 10

5/8" X 3/16"

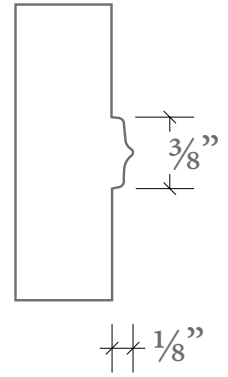

CTM | MU | 11

3/8" X 1/8"



PANEL MOLDING



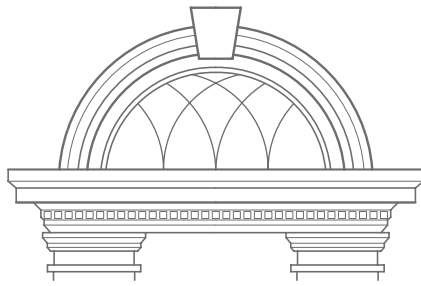

CT MOLDINGS

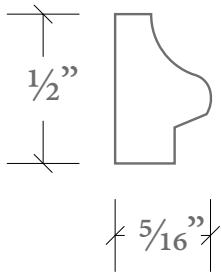

CTM | PM | 1

$\frac{1}{2}'' \times \frac{5}{16}''$

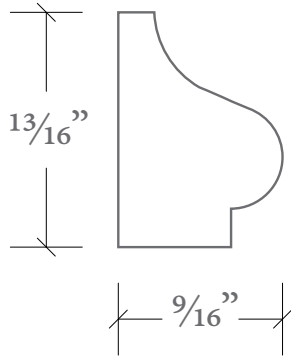

CTM | PM | 2 ●

$\frac{13}{16}'' \times \frac{9}{16}''$

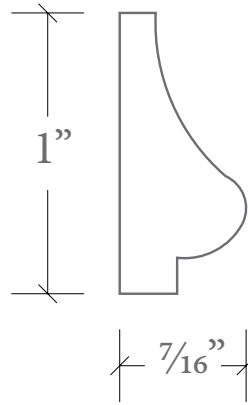

CTM | PM | 3

$1'' \times \frac{7}{16}''$

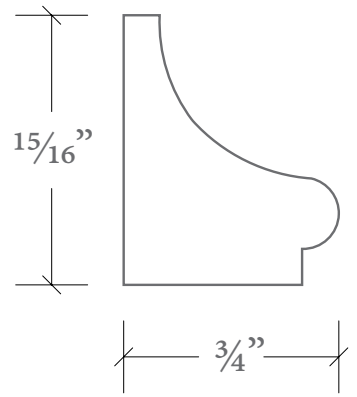

CTM | PM | 4 ●

$\frac{15}{16}'' \times \frac{3}{4}''$

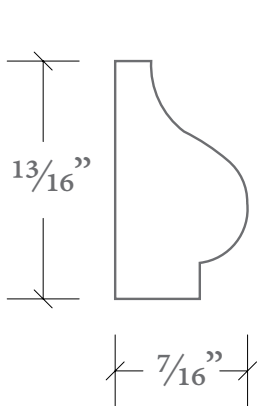

CTM | PM | 5

$\frac{13}{16}'' \times \frac{7}{16}''$

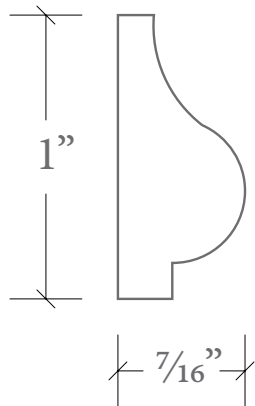

CTM | PM | 6

$1'' \times \frac{7}{16}''$

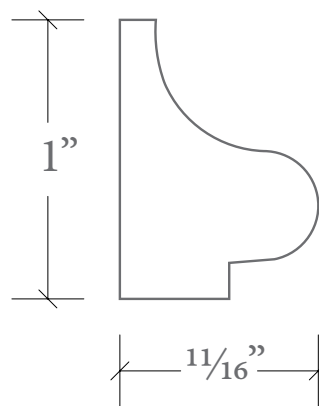

CTM | PM | 7

$1'' \times \frac{11}{16}''$

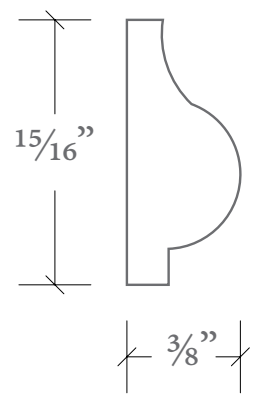

CTM | PM | 8 ●

$\frac{15}{16}'' \times \frac{3}{8}''$

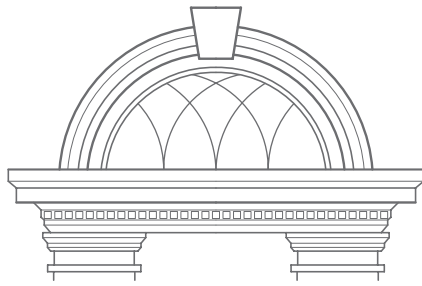

CT MOLDINGS

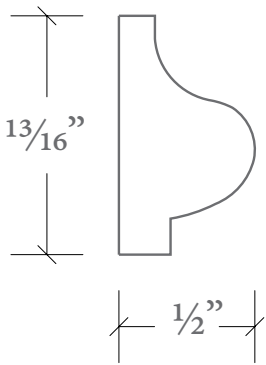

CTM | PM | 9

$13/16$ " x $1/2$ "

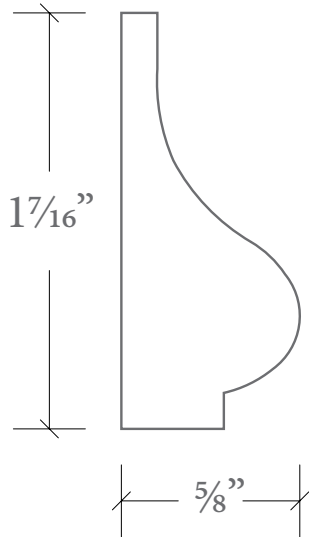

CTM | PM | 10

$1 7/16$ " x $5/8$ "

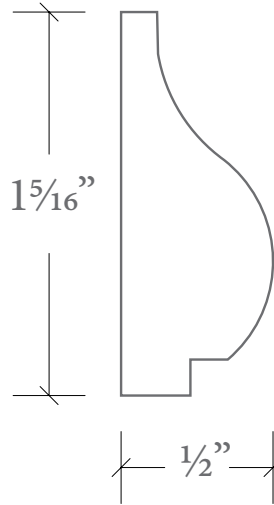

CTM | PM | 11 ●

$1 5/16$ " x $1/2$ "

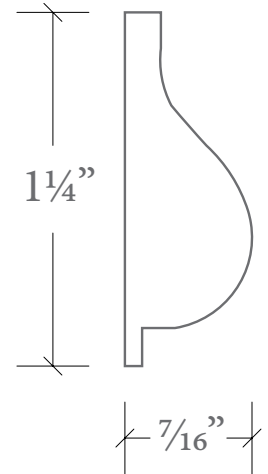

CTM | PM | 12

$1 1/4$ " x $7/16$ "

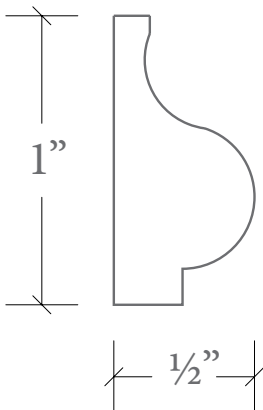

CTM | PM | 13 ●

1" x $1/2$ "

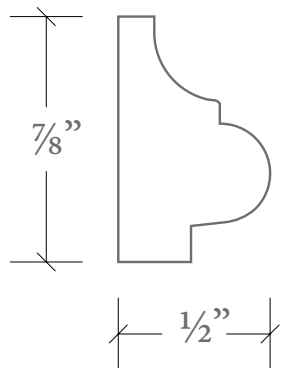

CTM | PM | 14

$7/8$ " x $1/2$ "

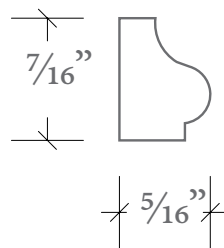

CTM | PM | 15

$7/16$ " x $5/16$ "

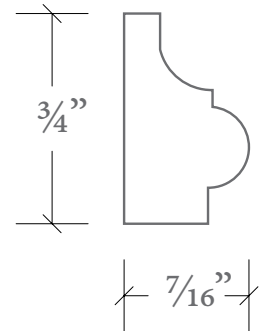

CTM | PM | 16

$3/4$ " x $7/16$ "

● Molding can be curved

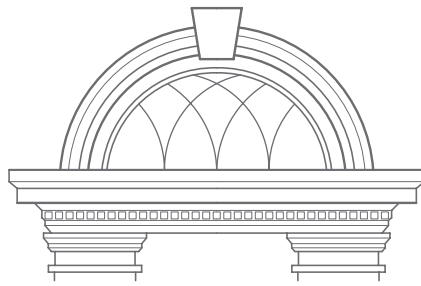

CT MOLDINGS

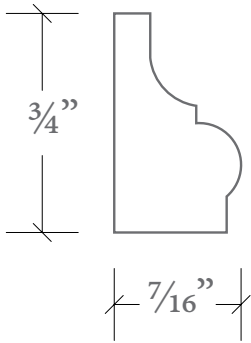

CTM | PM | 17 ●

$\frac{3}{4}'' \times \frac{7}{16}''$

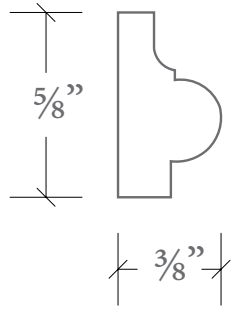

CTM | PM | 18

$\frac{5}{8}'' \times \frac{3}{8}''$

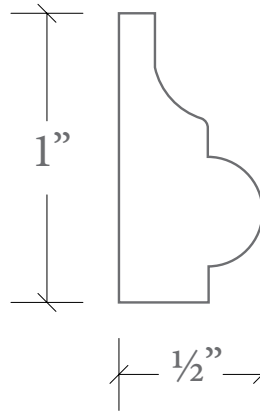

CTM | PM | 19 ●

$1'' \times \frac{1}{2}''$

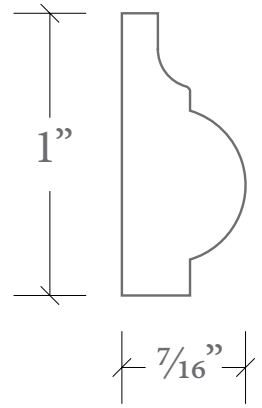

CTM | PM | 20

$1'' \times \frac{7}{16}''$

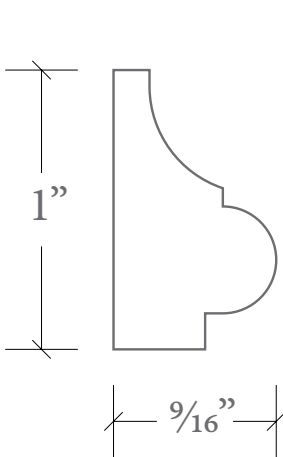

CTM | PM | 21 ●

$1'' \times \frac{9}{16}''$

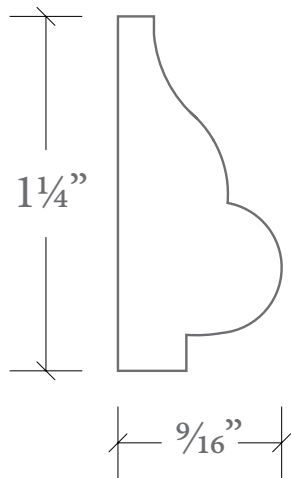

CTM | PM | 22

$1\frac{1}{4}'' \times \frac{9}{16}''$

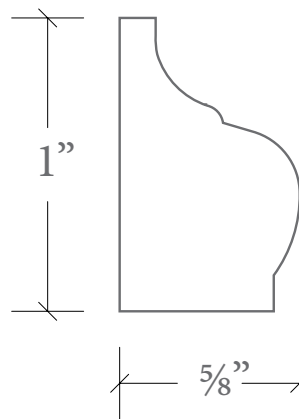

CTM | PM | 23 ●

$1'' \times \frac{5}{8}''$

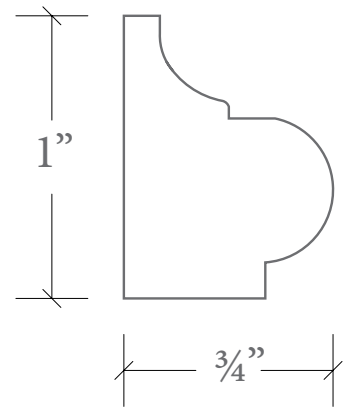

CTM | PM | 24

$1'' \times \frac{3}{4}''$

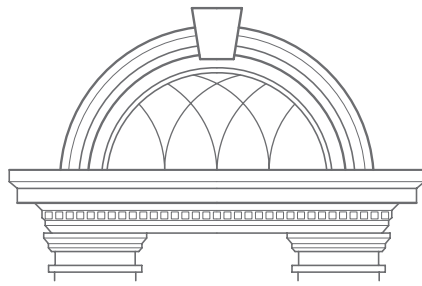

CT MOLDINGS

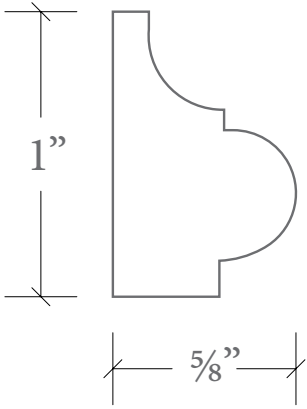

CTM | PM | 25

1" x 5/8"

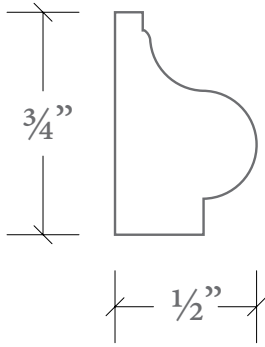

CTM | PM | 26

3/4" x 1/2"

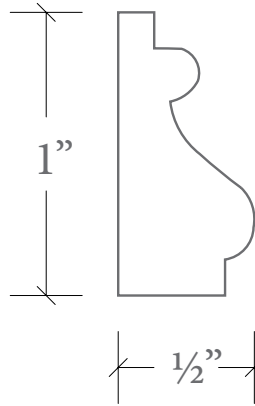

CTM | PM | 27

1" x 1/2"

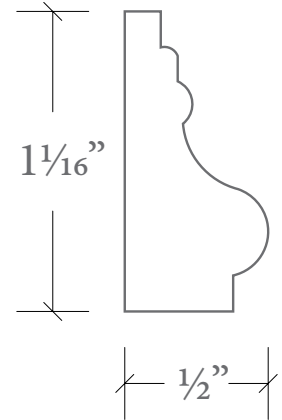

CTM | PM | 28 ●

1 1/16" x 1/2"

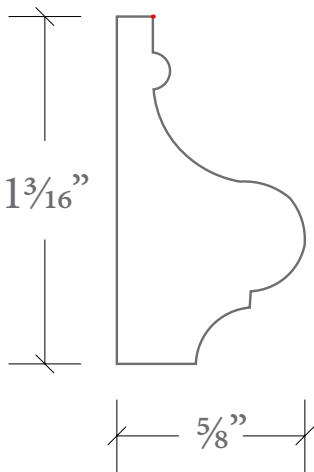

CTM | PM | 29

1 3/16" x 5/8"

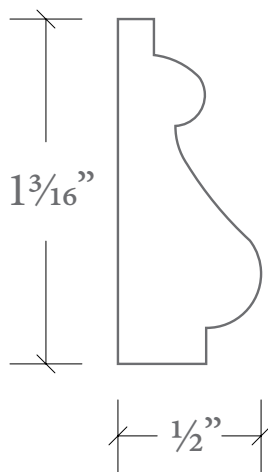

CTM | PM | 30

1 3/16" x 1/2"

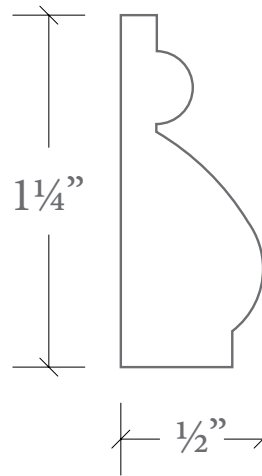

CTM | PM | 31 ●

1 1/4" x 1/2"

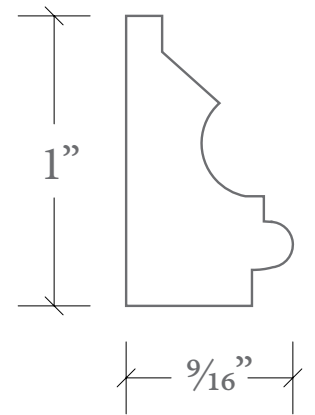

CTM | PM | 32

1" x 9/16"

● Molding can be curved

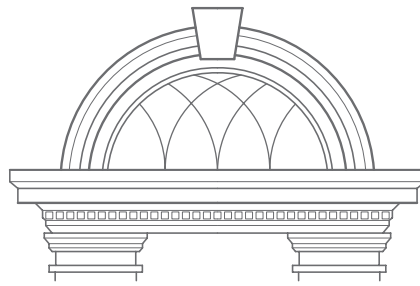

CT MOLDINGS

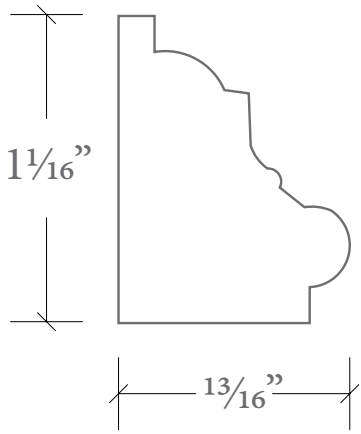

CTM | PM | 33

1 1/16" X 13/16"

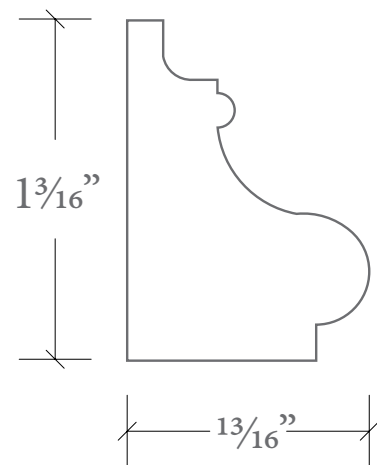

CTM | PM | 34

1 3/16" X 13/16"

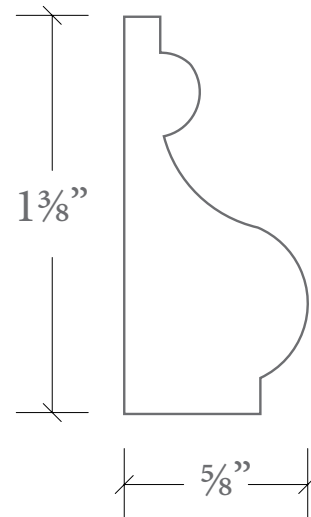

CTM | PM | 35

1 3/8" X 5/8"

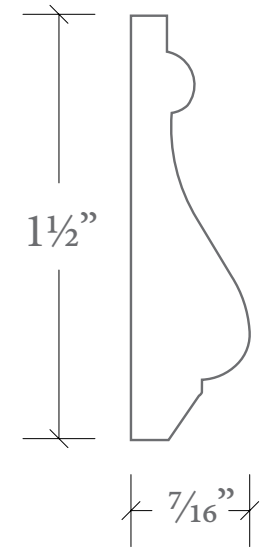

CTM | PM | 36

1 1/2" X 7/16"

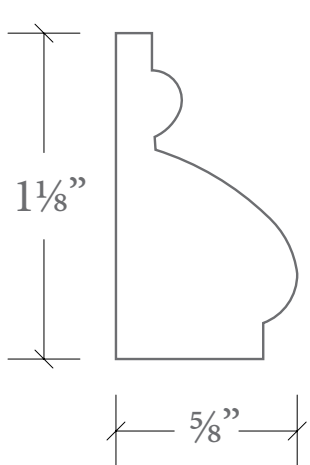

CTM | PM | 37

1 1/8" X 5/8"

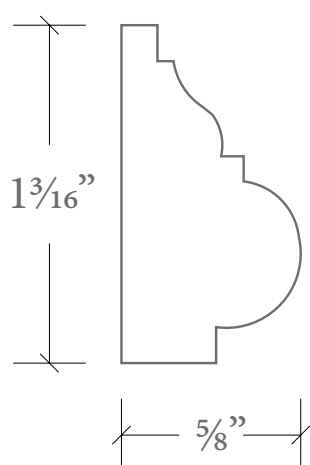

CTM | PM | 38

1 3/8" X 5/8"

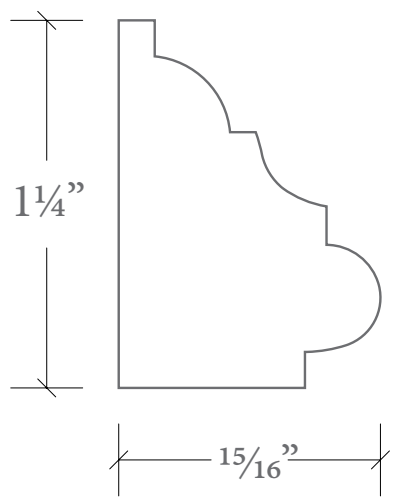

CTM | PM | 39

1 1/4" X 15/16"

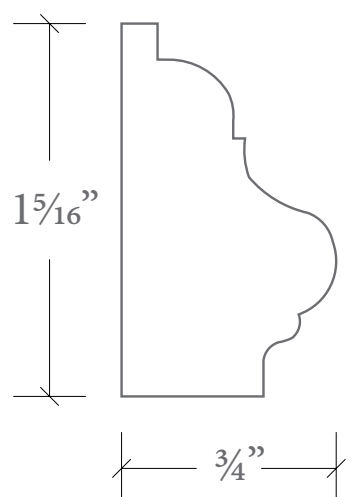

CTM | PM | 40

1 5/16" X 3/4"

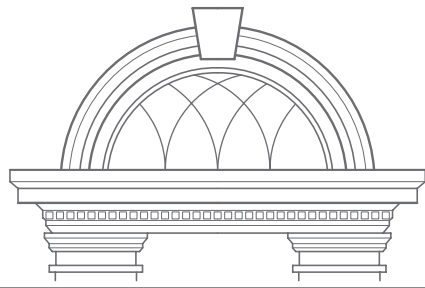

CT MOLDINGS

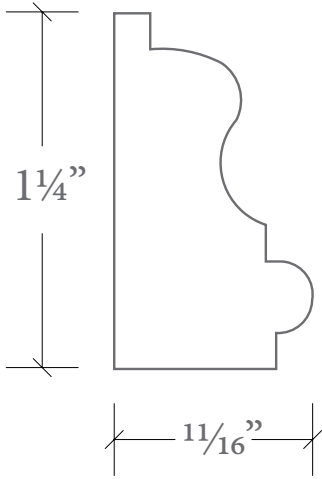

CTM | PM | 41

1 1/4" x 1 1/16"

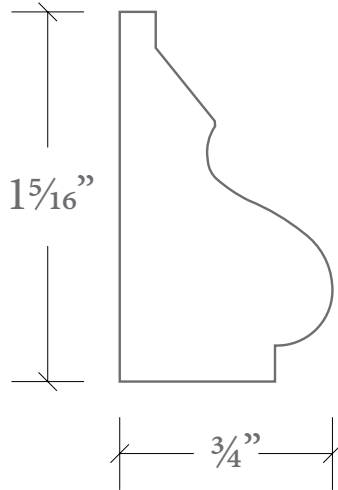

CTM | PM | 42

1 5/16" x 3/4"

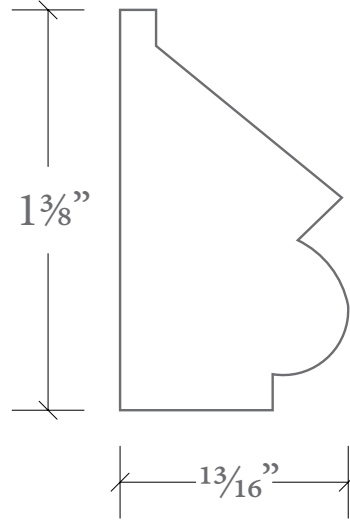

CTM | PM | 43

1 3/8" x 1 3/16"

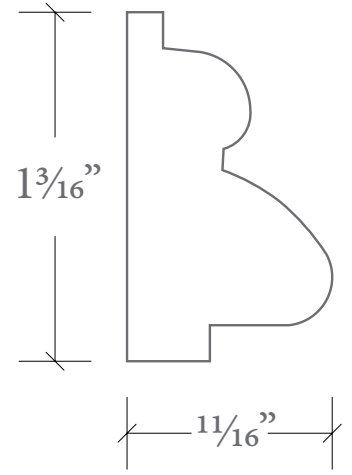

CTM | PM | 44

1 3/16" x 1 1/16"

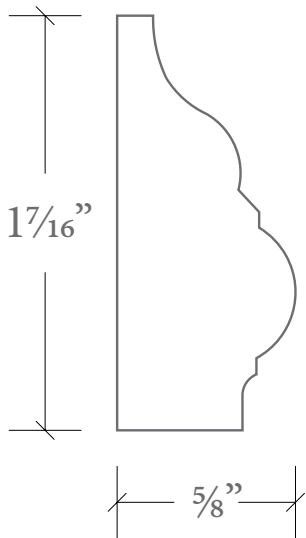

CTM | PM | 45

1 7/16" x 5/8"

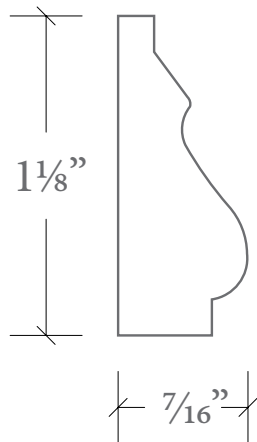

CTM | PM | 46

1 1/8" x 7/16"

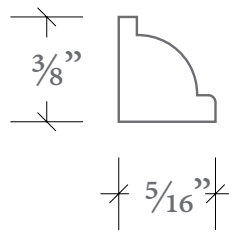

CTM | PM | 47

3/8" x 5/16"

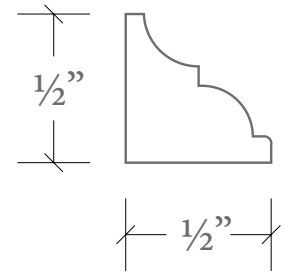

CTM | PM | 48

1/2" x 1/2"

● Molding can be curved

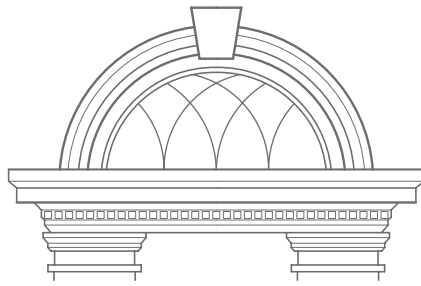

CT MOLDINGS

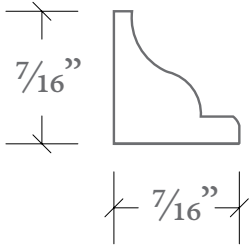

CTM | PM | 49 ●

$\frac{7}{16}$ " X $\frac{7}{16}$ "

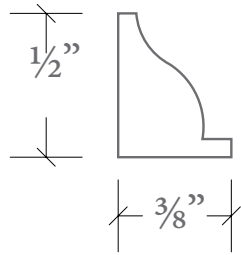

CTM | PM | 50

$\frac{1}{2}$ " X $\frac{3}{8}$ "

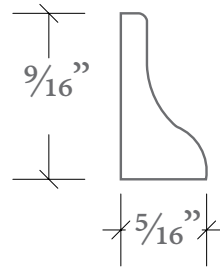

CTM | PM | 51

$\frac{9}{16}$ " X $\frac{5}{16}$ "

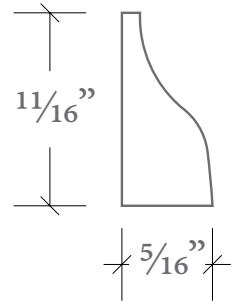

CTM | PM | 52

$1\frac{1}{16}$ " X $\frac{5}{16}$ "

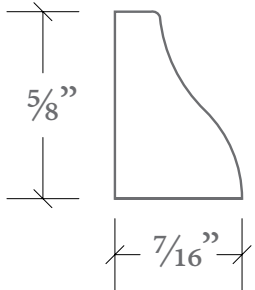

CTM | PM | 53

$\frac{5}{8}$ " X $\frac{7}{16}$ "

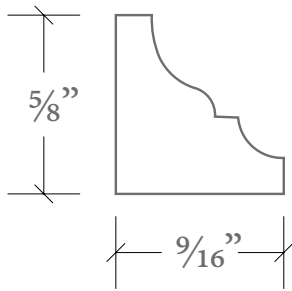

CTM | PM | 54

$\frac{5}{8}$ " X $\frac{9}{16}$ "

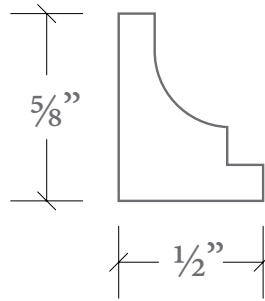

CTM | PM | 55

$\frac{5}{8}$ " X $\frac{1}{2}$ "

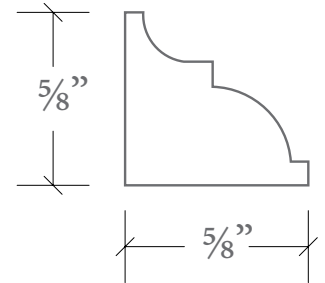

CTM | PM | 56

$\frac{5}{8}$ " X $\frac{5}{8}$ "

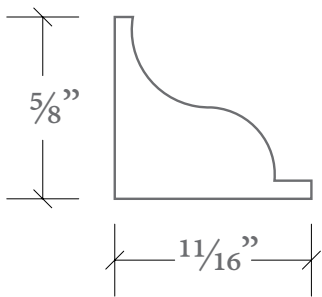

CTM | PM | 57

$\frac{5}{8}$ " X $1\frac{1}{16}$ "

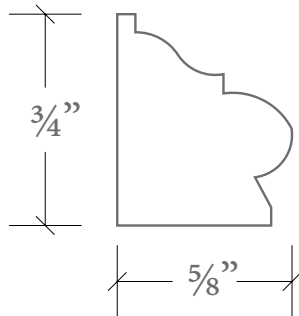

CTM | PM | 58

$\frac{3}{4}$ " X $\frac{5}{8}$ "

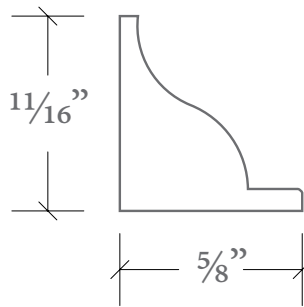

CTM | PM | 59

$1\frac{1}{16}$ " X $\frac{5}{8}$ "

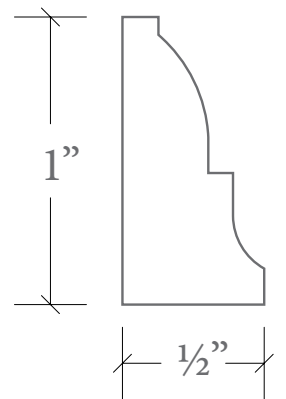

CTM | PM | 60

1" X $\frac{1}{2}$ "

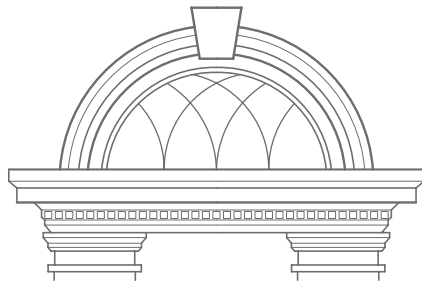

CT MOLDINGS

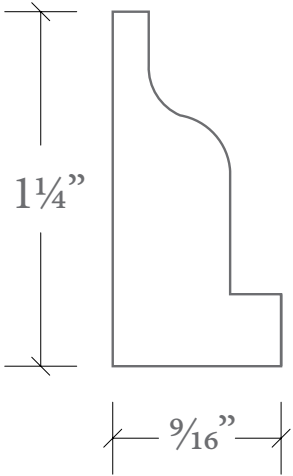

CTM | PM | 61 ●

1 1/4" x 9/16"

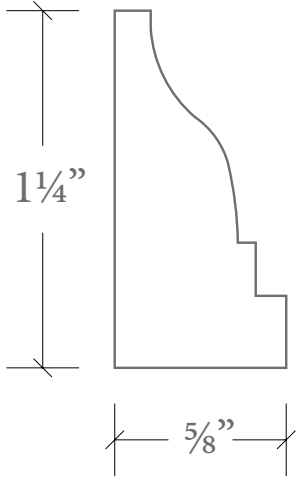

CTM | PM | 62

1 1/4" x 5/8"

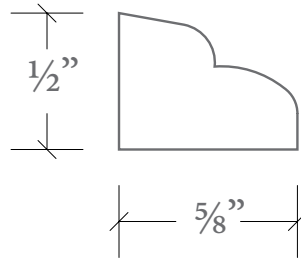

CTM | PM | 63

1/2" x 5/8"

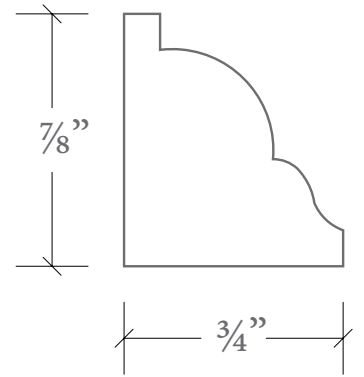

CTM | PM | 64

7/8" x 3/4"

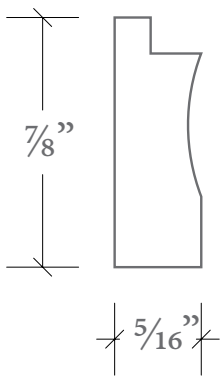

CTM | PM | 65

7/8" x 5/16"

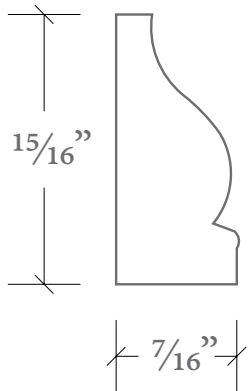

CTM | PM | 66

15/16" x 7/16"

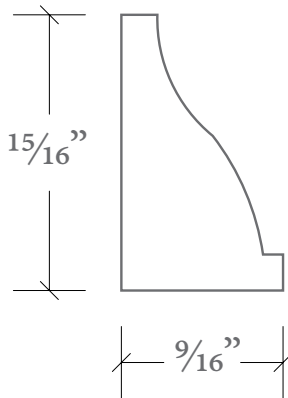

CTM | PM | 67

15/16" x 9/16"

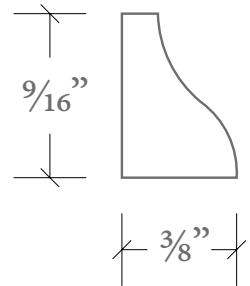

CTM | PM | 68

9/16" x 3/8"

● Molding can be curved

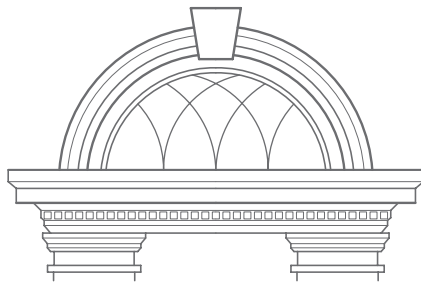

CT MOLDINGS

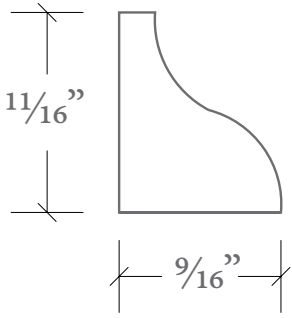

CTM | PM | 69

1 1/16" x 9/16"

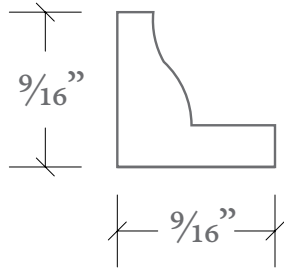

CTM | PM | 70

9/16" x 9/16"

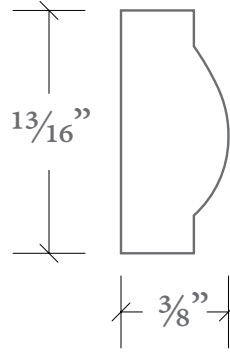

CTM | PM | 71 ●

1 3/16" x 3/8"

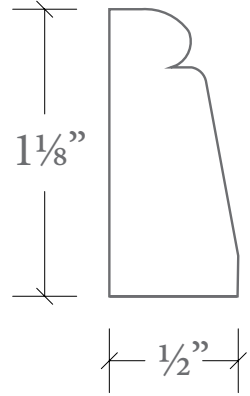

CTM | PM | 72

1 1/8" x 1/2"

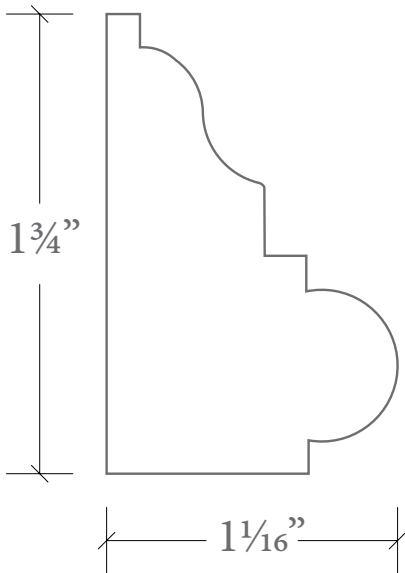

CTM | PM | 73

1 3/4" x 1 1/16"

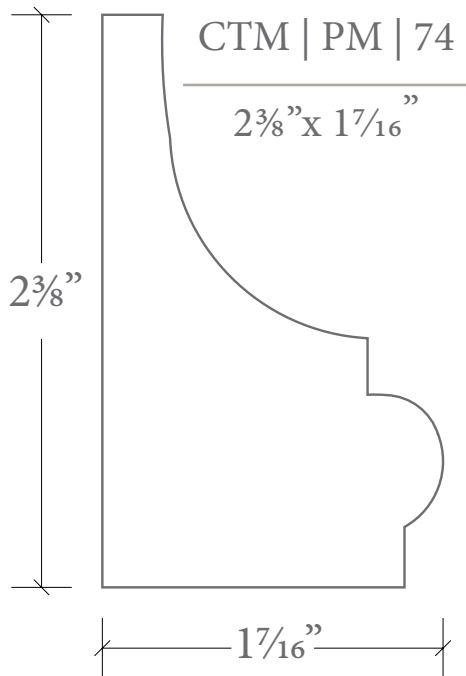

CTM | PM | 74

2 3/8" x 1 7/16"

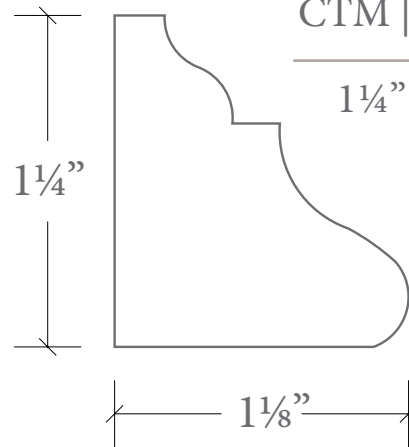

CTM | PM | 75

1 1/4" x 1 1/8"

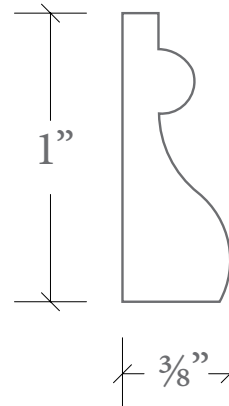

CTM | PM | 76

1" x 3/8"

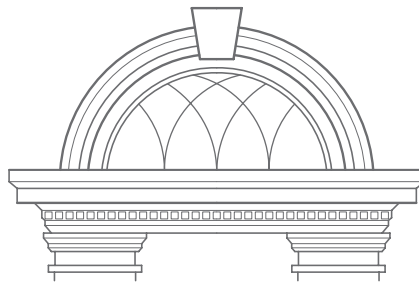

CT MOLDINGS

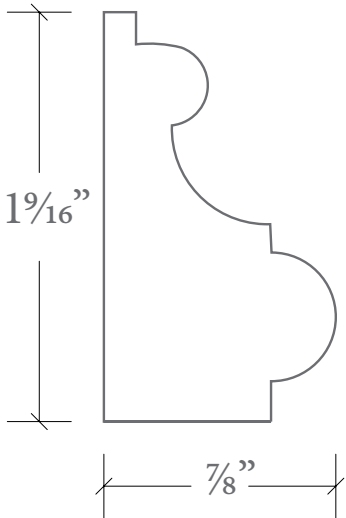

CTM | PM | 77

$1\frac{9}{16}'' \times \frac{7}{8}''$

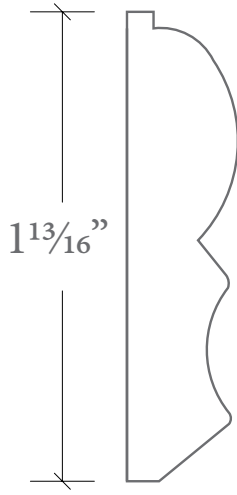

CTM | PM | 78

$1\frac{13}{16}'' \times \frac{3}{8}''$

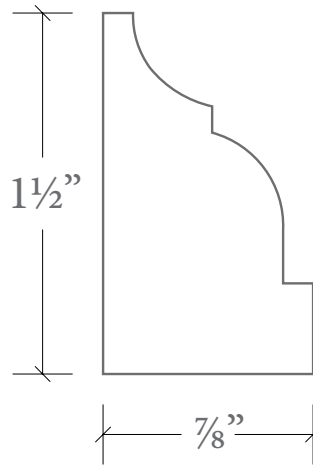

CTM | PM | 79

$1\frac{1}{2}'' \times \frac{7}{8}''$

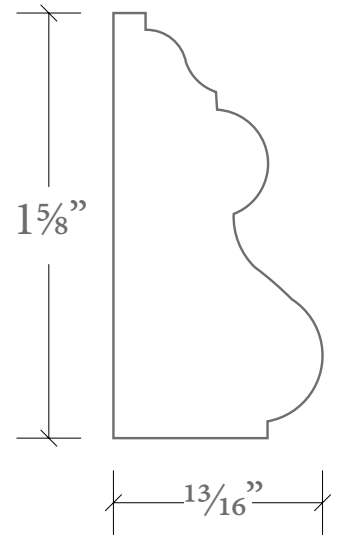

CTM | PM | 80

$1\frac{5}{8}'' \times 1\frac{3}{16}''$

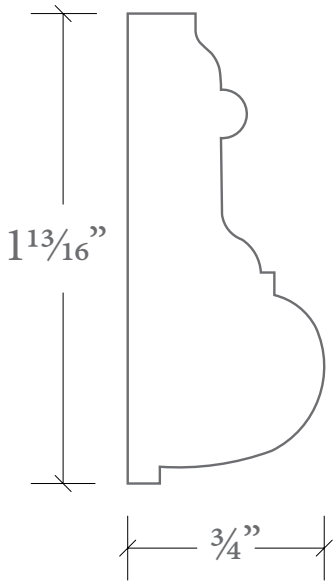

CTM | PM | 81

$1\frac{13}{16}'' \times \frac{3}{4}''$

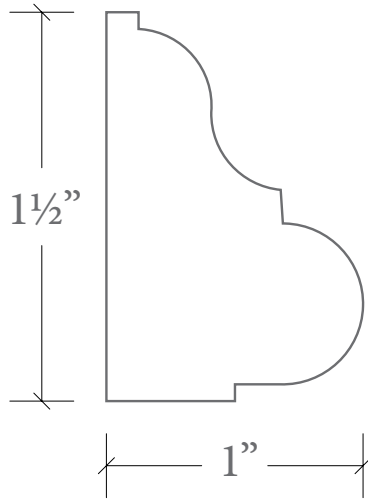

CTM | PM | 82

$1\frac{1}{2}'' \times 1''$

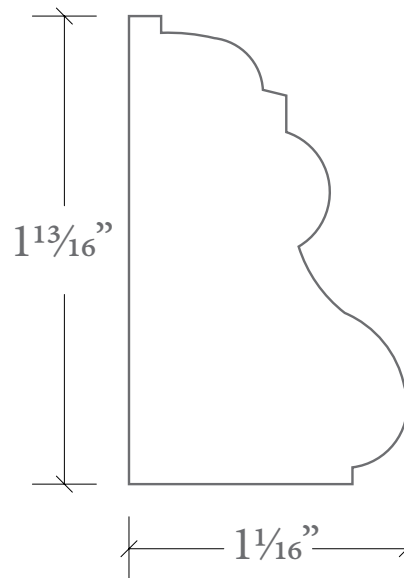

CTM | PM | 83

$1\frac{13}{16}'' \times 1\frac{1}{16}''$

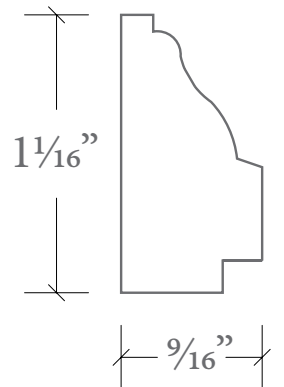

CTM | PM | 84 ●

$1\frac{1}{16}'' \times \frac{9}{16}''$

● Molding can be curved

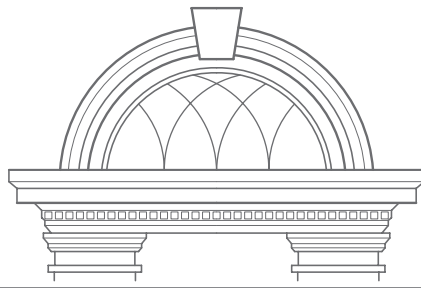

CT MOLDINGS

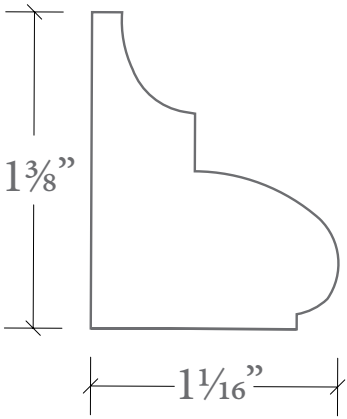

CTM | PM | 85

$1\frac{3}{8}'' \times 1\frac{1}{16}''$

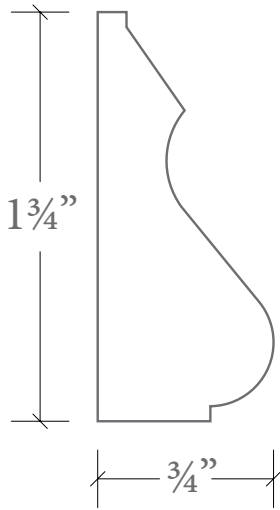

CTM | PM | 86

$1\frac{3}{4}'' \times \frac{3}{4}''$



CTM | PM | 87

$1\frac{3}{8}'' \times \frac{1}{2}''$

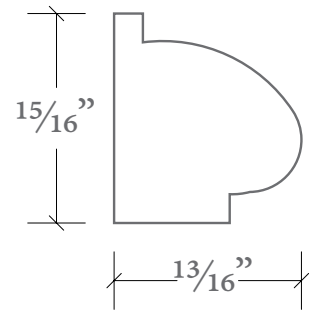

CTM | PM | 88

$\frac{15}{16}'' \times \frac{13}{16}''$

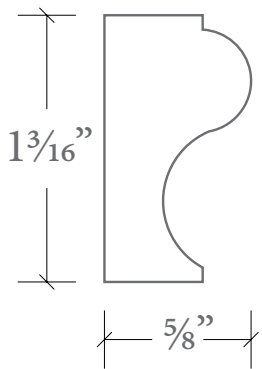

CTM | PM | 89

$1\frac{3}{16}'' \times \frac{5}{8}''$

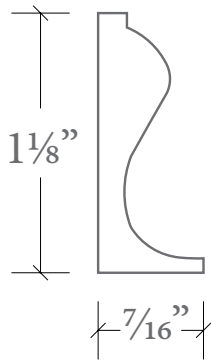

CTM | PM | 90

$1\frac{1}{8}'' \times \frac{7}{16}''$

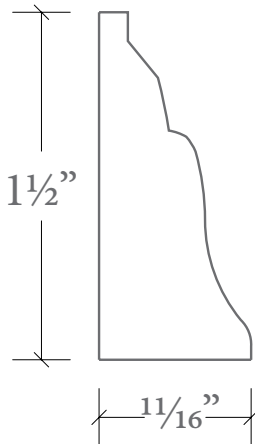

CTM | PM | 91 ●

$1\frac{1}{2}'' \times 1\frac{1}{16}''$

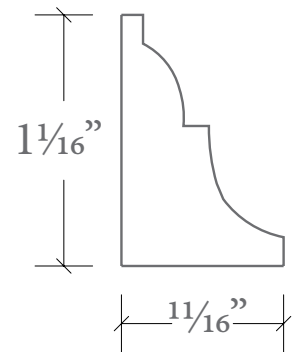

CTM | PM | 92

$1\frac{1}{16}'' \times 1\frac{1}{16}''$

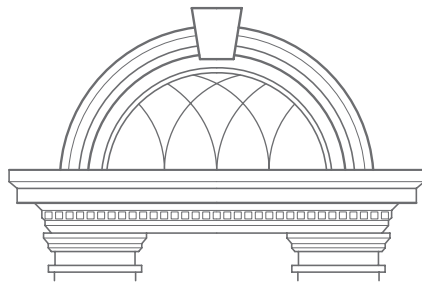

CT MOLDINGS

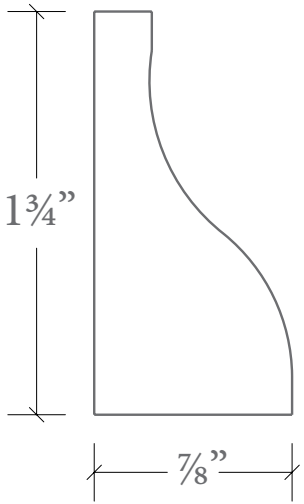

CTM | PM | 93

1 3/4" x 7/8"

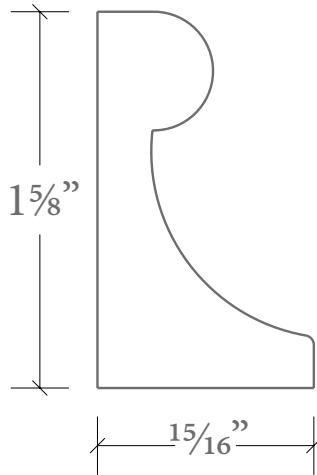

CTM | PM | 94 ●

1 5/8" x 15/16"

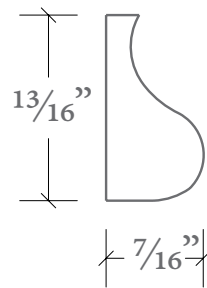

CTM | PM | 95

13/16" x 7/16"

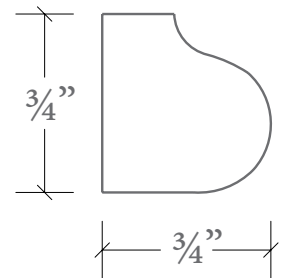

CTM | PM | 96 ●

3/4" x 3/4"

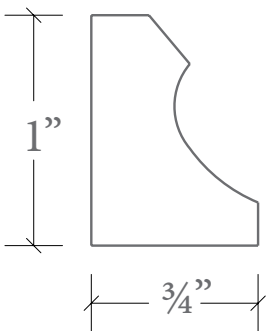

CTM | PM | 97 ●

1" x 3/4"

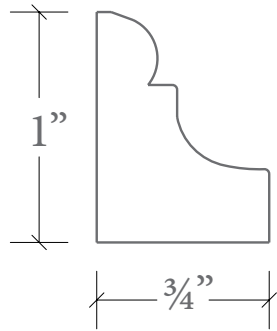

CTM | PM | 98

1" x 3/4"

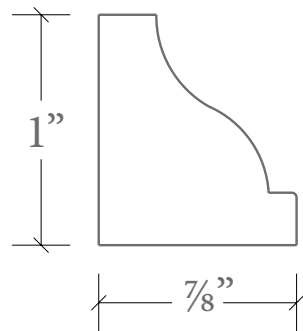

CTM | PM | 99 ●

1" x 7/8"

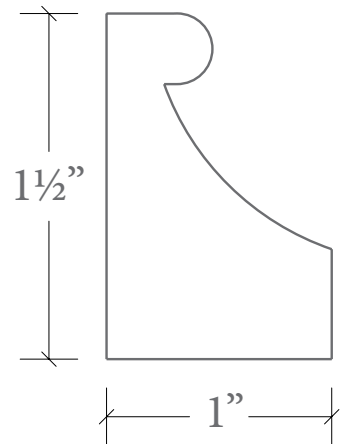

CTM | PM | 100

1 1/2" x 1"

● Molding can be curved

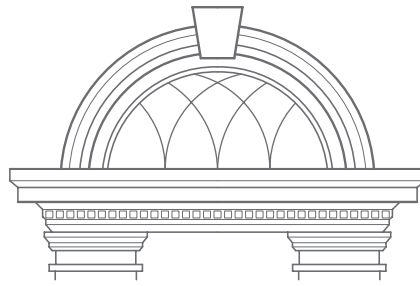

CT MOLDINGS

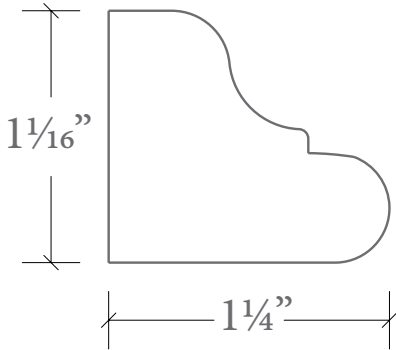

CTM | PM | 101 ●

1 1/16" x 1 1/4"

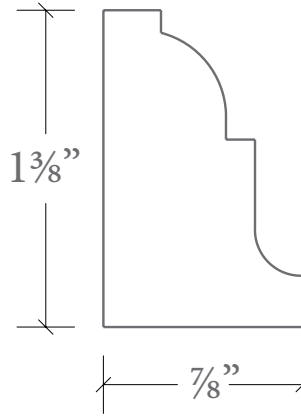

CTM | PM | 102 ●

1 3/8" x 7/8"

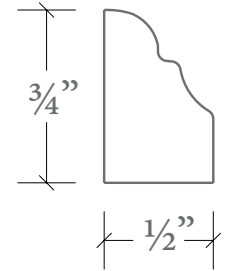

CTM | PM | 103 ●

3/4" x 1/2"

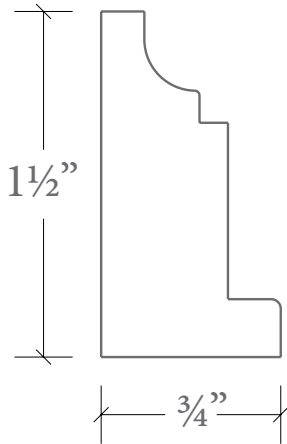

CTM | PM | 104 ●

1 1/2" x 3/4"

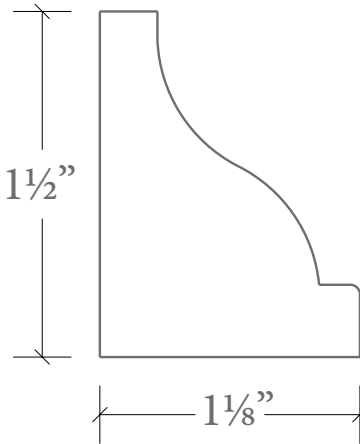

CTM | PM | 105 ●

1 1/2" x 1 1/8"

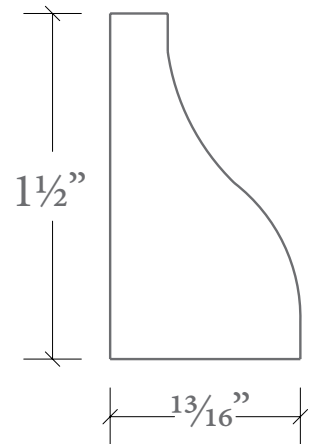

CTM | PM | 106

1 1/2" x 13/16"

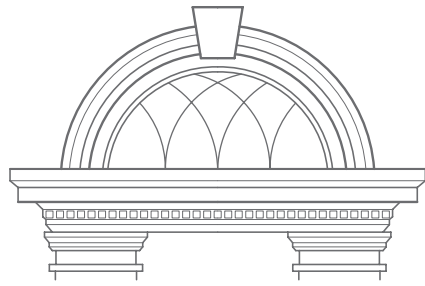

CT MOLDINGS

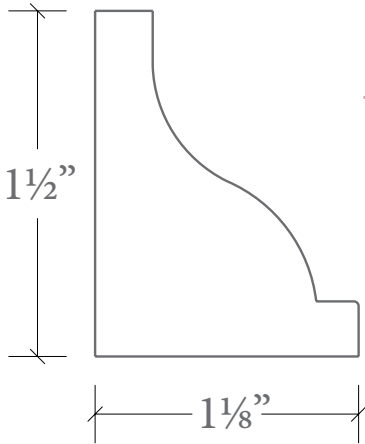

CTM | PM | 107 ●

1 1/2" x 1 1/8"

CTM | PM | 108 ●

2" x 1"

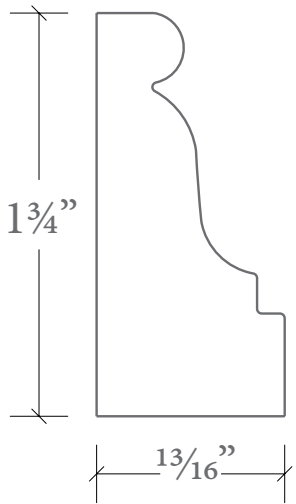
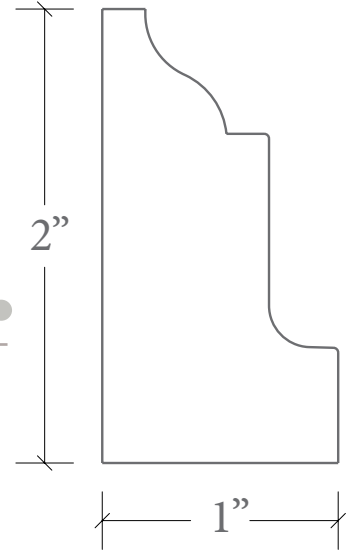

CTM | PM | 109 ●

1 3/4" x 13/16"

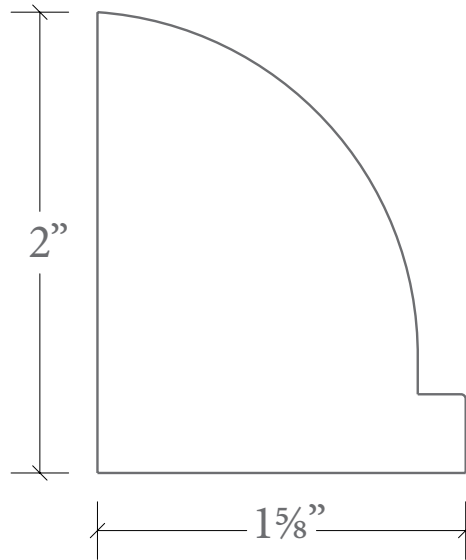

CTM | PM | 110

2" x 1 5/8"

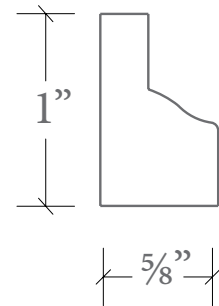

CTM | PM | 111

1" x 5/8"

CTM | PM | 112

1/2" x 3/8"

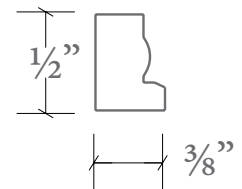

● Molding can be curved



CT MOLDINGS

PLINTH BLOCK

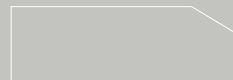
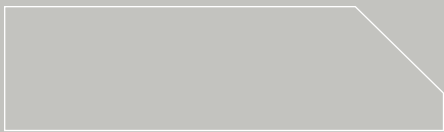
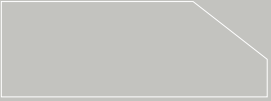
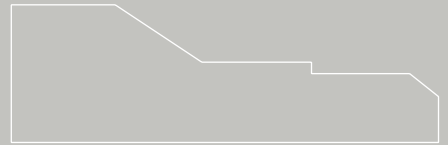

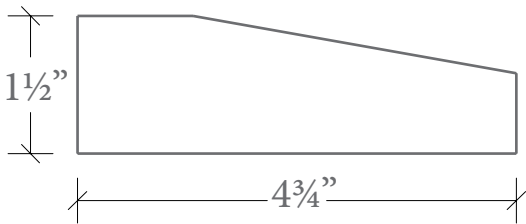
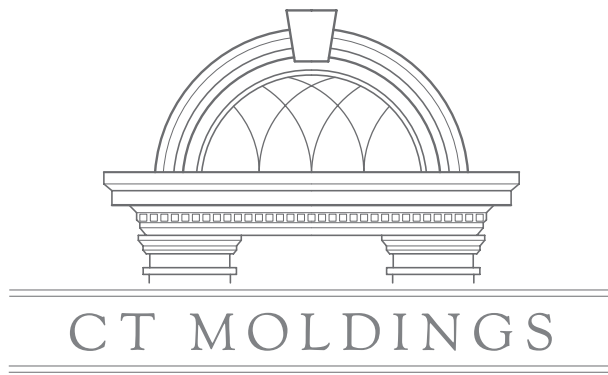

CTM | PL | 1

1 1/2" x 4 3/4"

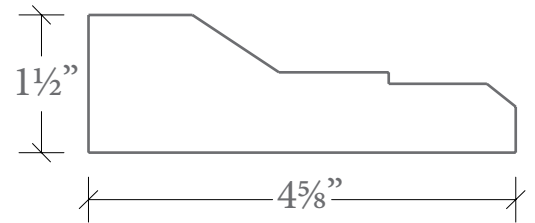

CTM | PL | 2

1 1/2" x 4 5/8"

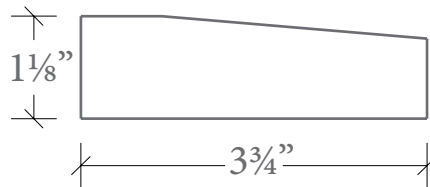

CTM | PL | 3

1 1/8" x 3 3/4"

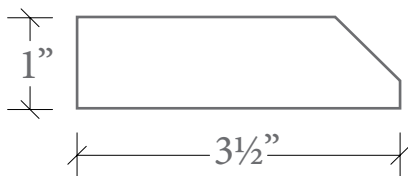

CTM | PL | 4

1" x 3 1/2"

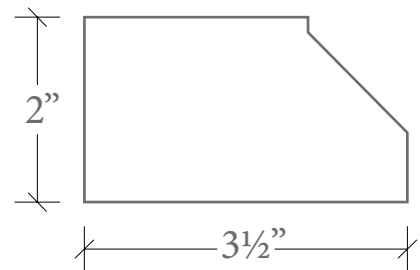

CTM | PL | 5

2" x 3 1/2"

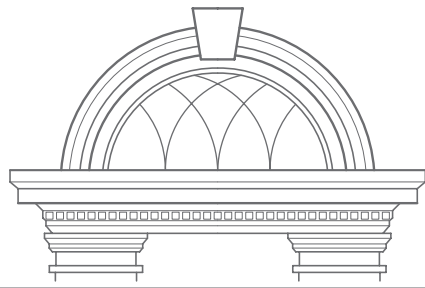

CT MOLDINGS

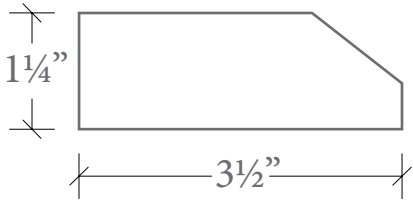

CTM | PL | 6

1 1/4" x 3 1/2"

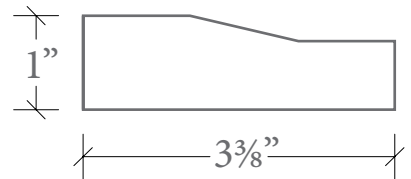

CTM | PL | 7

1" x 3 3/8"

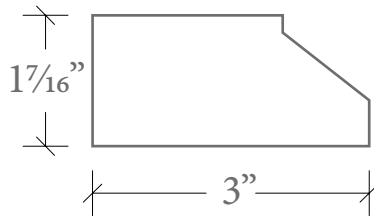

CTM | PL | 8

1 7/16" x 3"

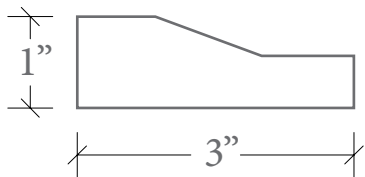

CTM | PL | 9

1" x 3"

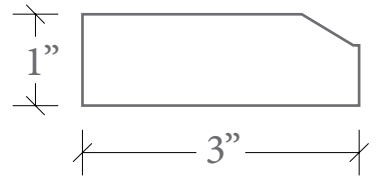

CTM | PL | 10

1" x 3"

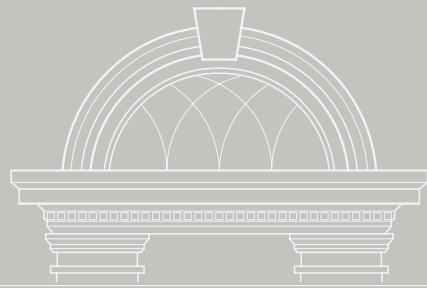

CT MOLDINGS

RAISED PANEL



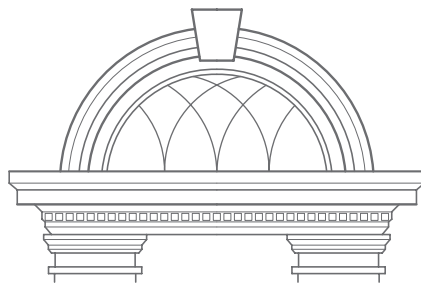

CT MOLDINGS

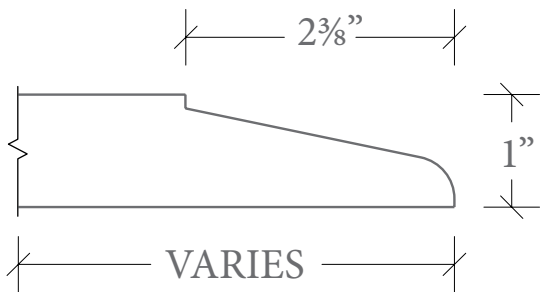

CTM | RP | 1

2 3/8" x 1"

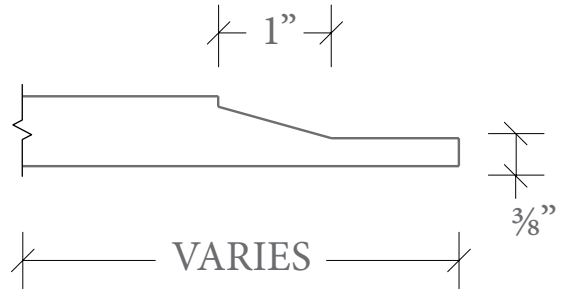

CTM | RP | 2

1" x 3/8"

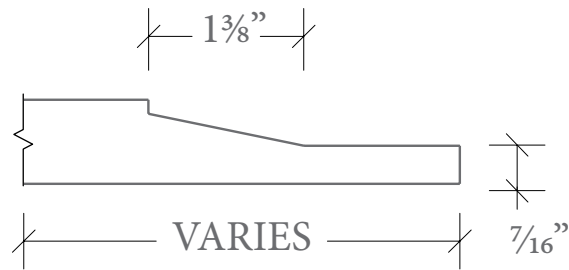

CTM | RP | 3

1 3/8" x 7/16"

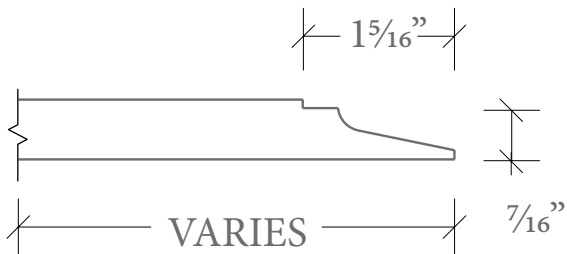

CTM | RP | 4

1 5/16" x 7/16"

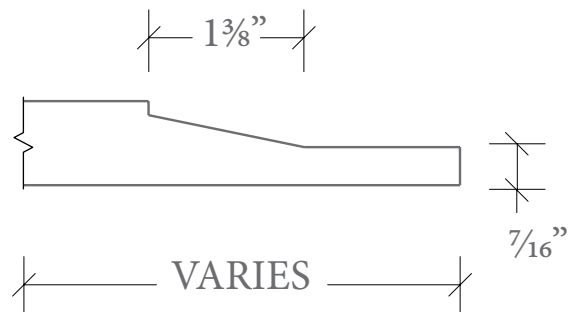

CTM | RP | 5

1 3/8" x 7/16"

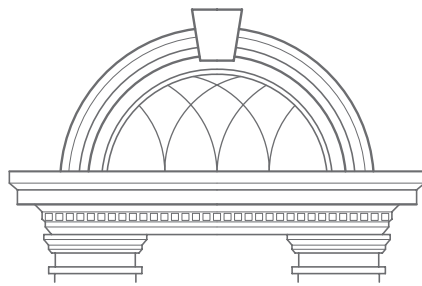

CT MOLDINGS

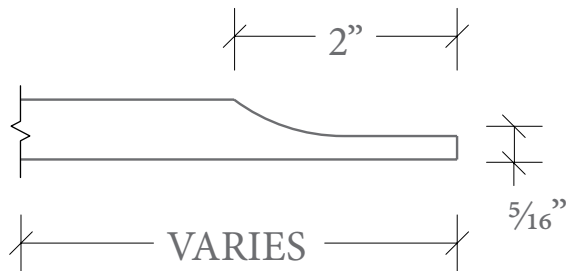

CTM | RP | 6

2" x 5/16"

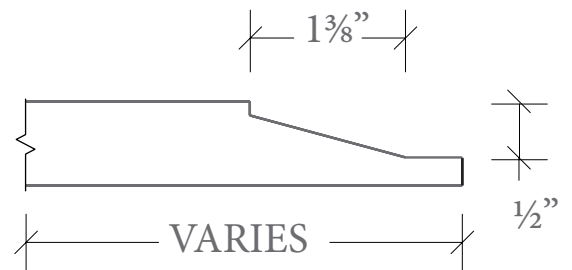

CTM | RP | 7

1 3/8" x 1/2"

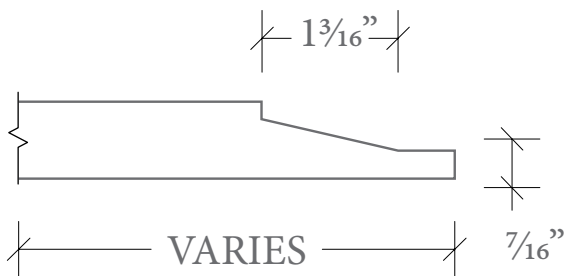

CTM | RP | 8

1 3/16" x 7/16"

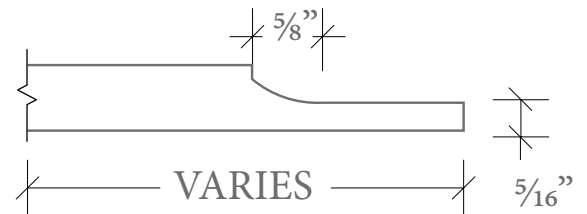

CTM | RP | 9

5/8" x 5/16"



SHOE MOLDING



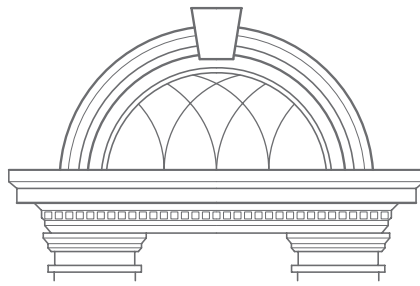

CT MOLDINGS

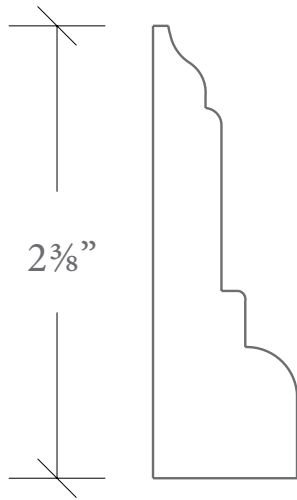

2 3/8"

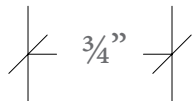

CTM | SH | 01

2 3/8" x 3/4"

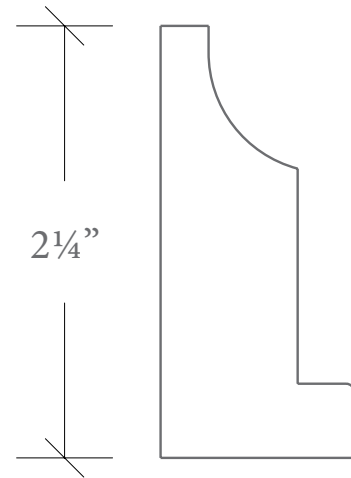

2 1/4"

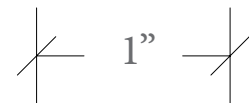

CTM | SH | 02

2 1/4" x 1"

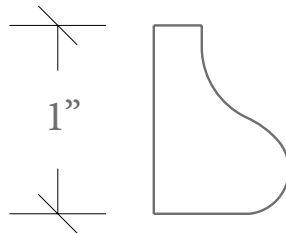

1"

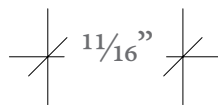

CTM | SH | 03

1" x 1 1/16"

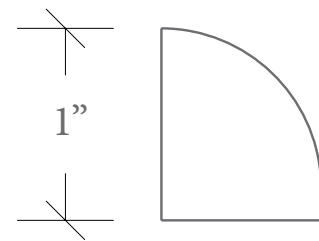

1"

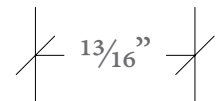

CTM | SH | 05

1" x 1 3/16"

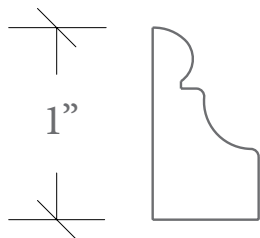

1"

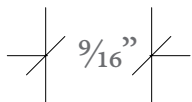

CTM | SH | 04

1" x 9/16"

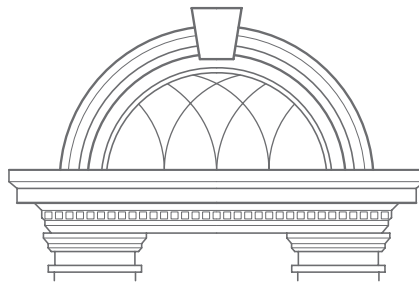

CT MOLDINGS

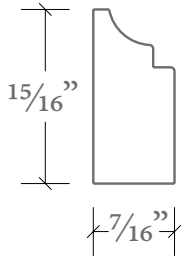

CTM | SH | 06

$15/16$ " X $7/16$ "

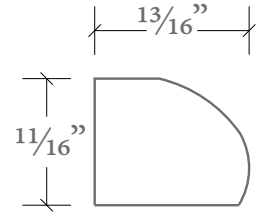

CTM | SH | 07

$11/16$ " X $13/16$ "

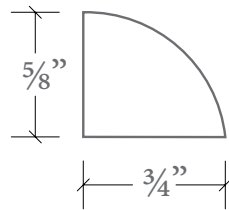

CTM | SH | 08

$5/8$ " X $3/4$ "

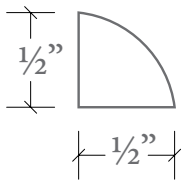

CTM | SH | 09

$1/2$ " X $1/2$ "

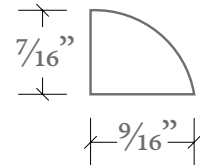

CTM | SH | 10

$7/16$ " X $9/16$ "

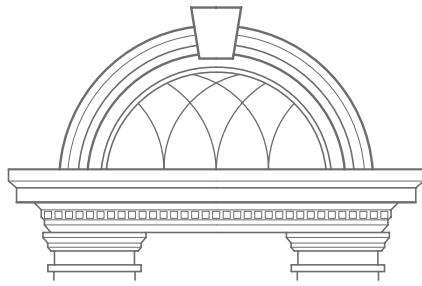

CT MOLDINGS

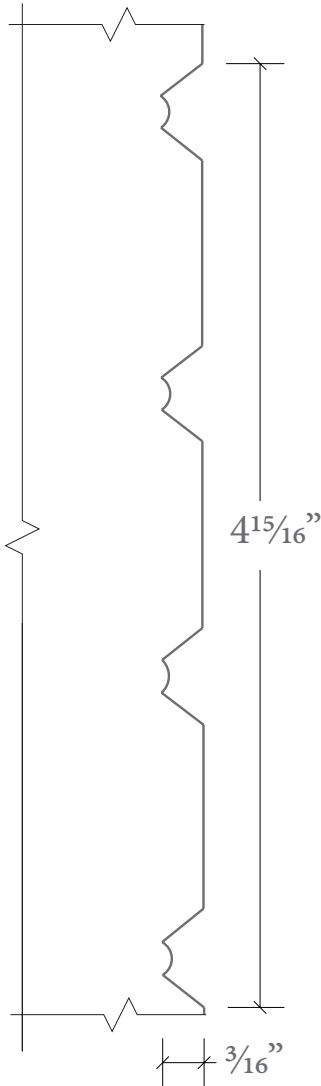

CTM | WA | 01

4¹⁵/₁₆" X 3/₁₆"

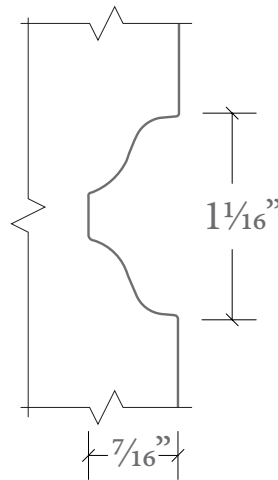

CTM | WA | 02

1¹/₁₆" X 7/₁₆"

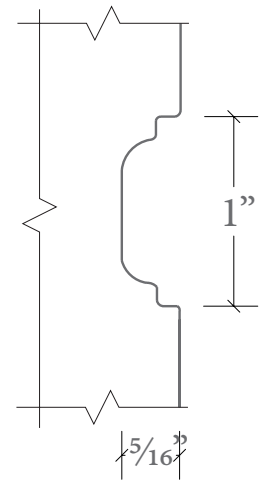

CTM | WA | 03

1" X 5/₁₆"

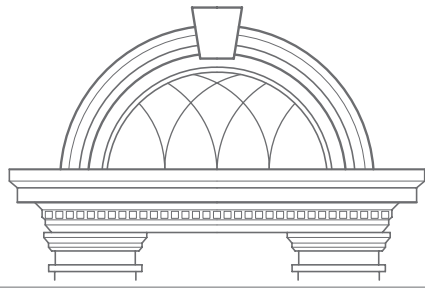

CT MOLDINGS

CTM | WA | 04

$1\frac{1}{16}'' \times \frac{1}{4}''$

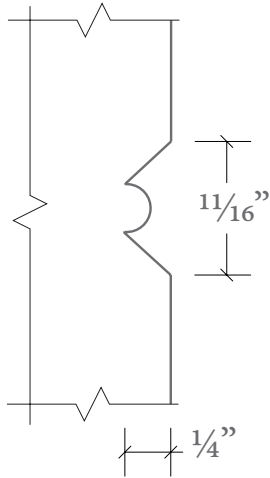

CTM | WA | 05

$\frac{5}{8}'' \times \frac{3}{8}''$

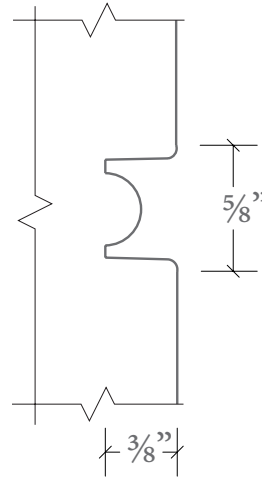

CTM | WA | 06

$\frac{9}{16}'' \times \frac{3}{8}''$

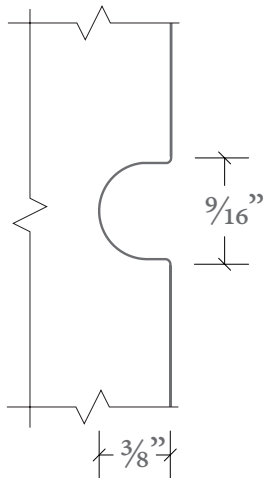

CTM | WA | 07

$\frac{5}{16}'' \times \frac{1}{4}''$

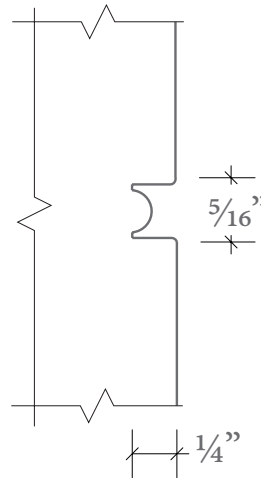

MOLDING & MILLWORK CATALOG

spring 2017



CT MOLDINGS,inc

308 Bishop Ave. Bridgeport, CT 06610
office (203) 612 - 4922 | fax (203) 612 - 4923
info@ctmoldings.com

www.ctmoldings.com
